

Review these instructions completely before beginning installation.  
Questions - call customer service 855-DOLLE US or 763-452-7492  
- Monday - Friday 8:00-5:00 central time. [info@dolleusa.com](mailto:info@dolleusa.com).  
Metric tools required.

Revise estas instrucciones en su totalidad antes de iniciar la instalación.  
Si tiene alguna pregunta, llame al servicio al cliente al 855-DOLLE desde  
los EE.UU o al 763-746-7830 de lunes a viernes de 8:00 a 5:00, hora  
central de los EE.UU. [info@dolleusa.com](mailto:info@dolleusa.com).  
Se necesitan herramientas métricas.

Local building codes vary. Please consult with your  
local officials for specific requirements.

Las normas de construcción locales pueden variar.  
Póngase en contacto con los técnicos locales para  
conocer los requisitos locales.

# Part list • Parte de la lista

## Components & Number of Each Component

Please check that all items are included before assembly

## Componentes y Número de cada componente

Verifique que todos los componentes estén incluidos antes de la entrega

1

26 1/4"  
[667mm]

$\phi$  4 1/2"  
[114mm]

13 13/16"  
[350mm]

x 13  
K2-1066940

2

R26 1/4"  
[666mm]

1 3/8"  
[35mm]

13 13/16"  
[351mm]

x 13  
K1-1066993 R  
K1-1066994 L

3

$\phi$  4 1/2"  
[114mm]

29 11/16"  
[755mm]

29 11/16"  
[754mm]

x 1  
K2-1066941 R  
K2-1066942 L

4

R29 11/16"  
[754mm]

1 3/8"  
[35mm]

29 11/16"  
[754mm]

x 1  
K1-1066995

5

39 7/8"  
[1013mm]

2 5/16"  
[58mm]

1 9/16"  
[40mm]

x 2  
K2-1066930

6

45 3/8"  
[1152mm]

13/16"  
[20mm]

1 9/16"  
[40mm]

x 7  
K2-1066932

7

$\phi$  2 3/8"  
[60mm]

35 13/16"  
[910mm]

$\phi$  7 7/8"  
[200mm]

x 1  
K2-71010

8

$\phi$  2 3/8"  
[60mm]

55 1/2"  
[1410mm]

x 1  
K2-71014

9

$\phi$  4 1/2"  
[114mm]

39"  
[990mm]

x 1  
K2-1066902

10

1 9/16"  
[40mm]

x 4  
K1-1066952

11

3/16"  
[5mm]

$\phi$  4 1/2"  
[115mm]

x 70  
K1-1066909

12

$\phi$  2 3/8"  
[60mm]

29 1/2"  
[750mm]

x 1  
K2-1066964

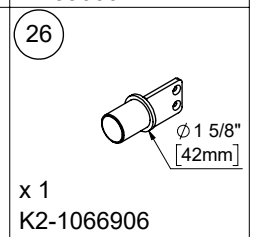
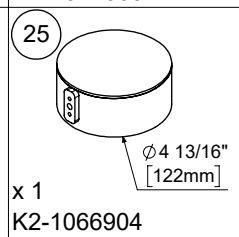
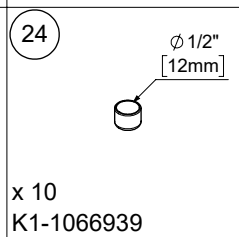
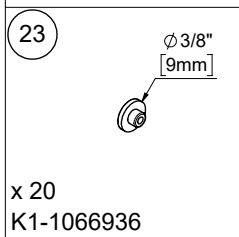
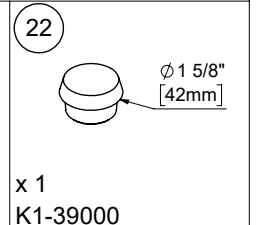
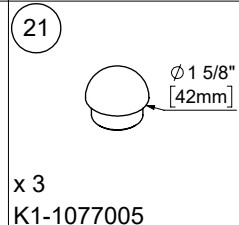
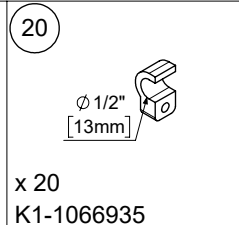
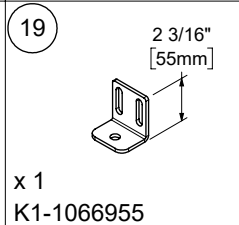
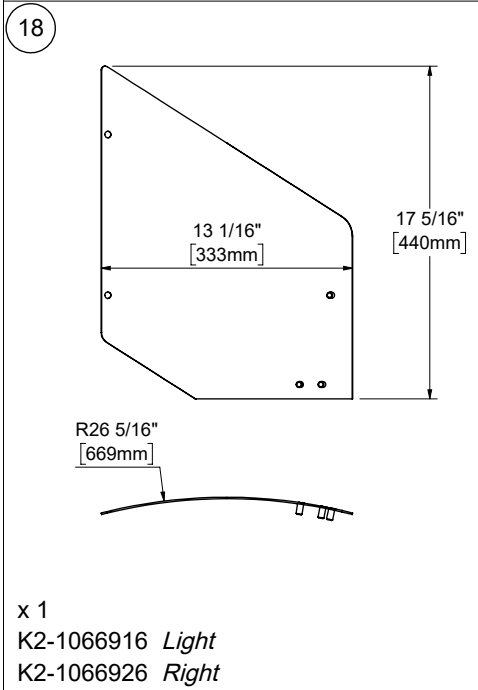
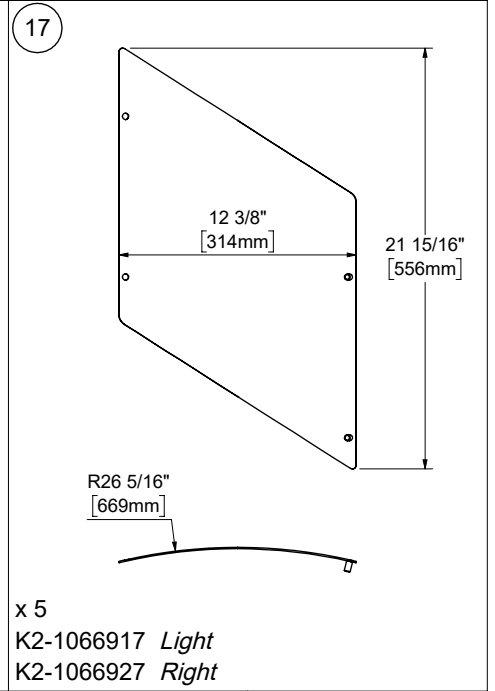
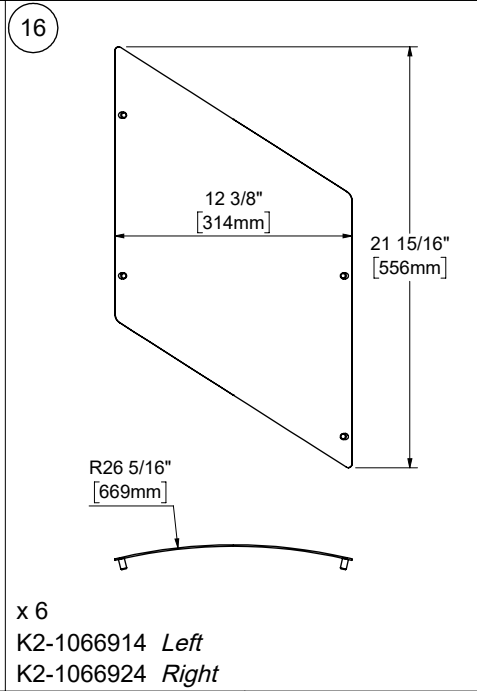
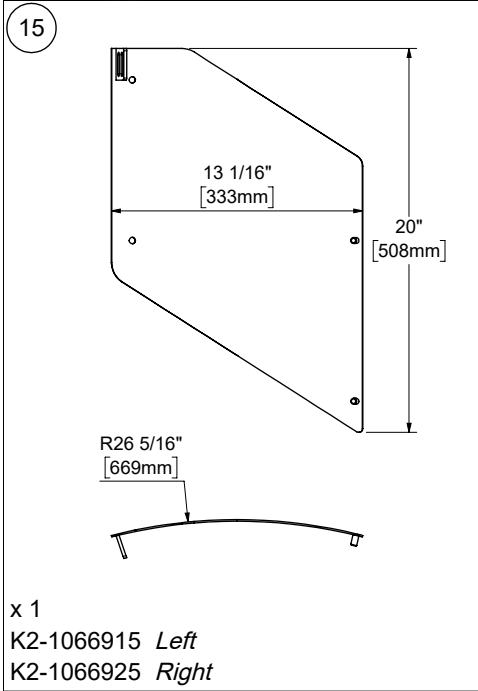
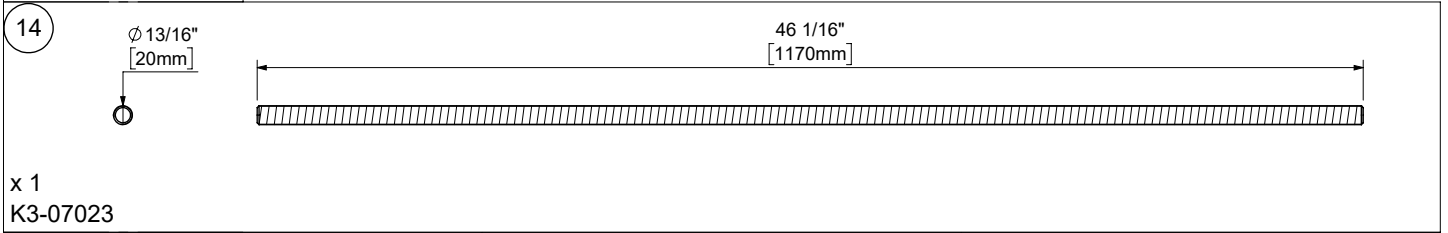
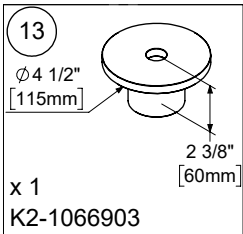

<p>27</p> <p><math>\phi 1\ 5/8"</math> [42mm]</p> <p>x 1 K1-1066959 19'-8 1/4" [6000mm]</p>		<p>28</p> <p>x 2 K1-1066938 19'-8 1/4" [6000mm]</p> <p><math>\phi 1/2"</math> [12mm]</p>		<p>29</p> <p>31 1/2" [800mm]</p> <p><math>\phi 1/2"</math> [12mm]</p> <p>x 3 K1-1066937</p>	
<p>30</p> <p><math>\phi 1\ 5/8"</math> [42mm]</p> <p>31 1/2" [800mm]</p> <p>x 1 K1-1066958</p>			<p>31</p> <p>x 2 K2-1066901</p> <p><math>\phi 8\ 1/4"</math> [210mm]</p>	<p>32</p> <p><math>\phi 2\ 3/8"</math> [60mm]</p> <p>x 1 K1-1066965</p>	
<p>40</p> <p>x 100 K3-10355 <math>\phi 6\ x\ 35\text{mm}</math> - Torx 30</p>	<p>41</p> <p>x 4 K3-02034 M6 x 12mm</p>	<p>42</p> <p>x 4 K3-10403 <math>\phi 6\ x\ 40\text{mm}</math> - Torx 25</p>	<p>43</p> <p>x 8 K3-08004 <math>\phi 10\ x\ 60\text{mm}</math></p>		
<p>45</p> <p>x 8 K3-06015 <math>\phi 8\ x\ 70\text{mm}</math></p>	<p>46</p> <p>x 58 K3-10402 <math>\phi 8\text{mm}</math> RAL 9005</p>	<p>47</p> <p>1/2" [13mm]</p> <p>x 58 K1-01014</p>	<p>48</p> <p>x 53 K3-03028 M8mm</p>	<p>49</p> <p>x 2 K3-10432 M6mm RAL 9005</p>	<p>50</p> <p>x 2 K3-10408 M6 x 16mm</p>
<p>51</p> <p>x 14 K1-1066934 M8 x 35mm</p>	<p>52</p> <p>x 7 K3-10436 M6 x 16mm RAL 9005</p>	<p>53</p> <p>x 20 K3-02016 M5 x 12mm</p>	<p>54</p> <p>x 2 K3-10484 M5 x 12mm RAL 9005</p>	<p>55</p> <p>x 2 K3-04020 <math>\phi 20\text{mm}</math></p>	<p>56</p> <p>x 2 K3-03024 M20mm</p>
<p>57</p> <p>x 1 K3-05003 M8 x 6mm</p>	<p>58</p> <p>x 2 K3-10441 M4 x 10mm RAL 9005</p>	<p>69</p> <p>x 1 R1-63272 <math>\phi 6\ x\ 25\text{mm}</math></p>			

**IMPORTANT:** DO NOT USE PARTS OTHER THAN THOSE INCLUDED WITH THE PRODUCT. REPLACEMENT PARTS PURCHASED LOCALLY MUST BE METRIC. IN CASE PARTS HAVE BEEN LOST OR DAMAGED CONTACT DOLLE USA INC. FOR REPLACEMENT.

**IMPORTANTE:** NO UTILICE PIEZAS DIFERENTES DE LAS SUMINISTRADAS CON EL PRODUCTO. LAS PIEZAS DE RECAMBIO ADQUIRIDAS POR SEPARADO DEBEN SER MÉTRICAS. EN CASO DE PÉRDIDA DE PIEZAS O DE PIEZAS DAÑADAS, PÓNGASE EN CONTACTO CON DOLLE USA INC.

## Tools required • Herramientas necesarias

Metric tools required for installation • Herramientas métricas necesarias para la instalación

NOT SUPPLIED • NO SUMINISTRADAS

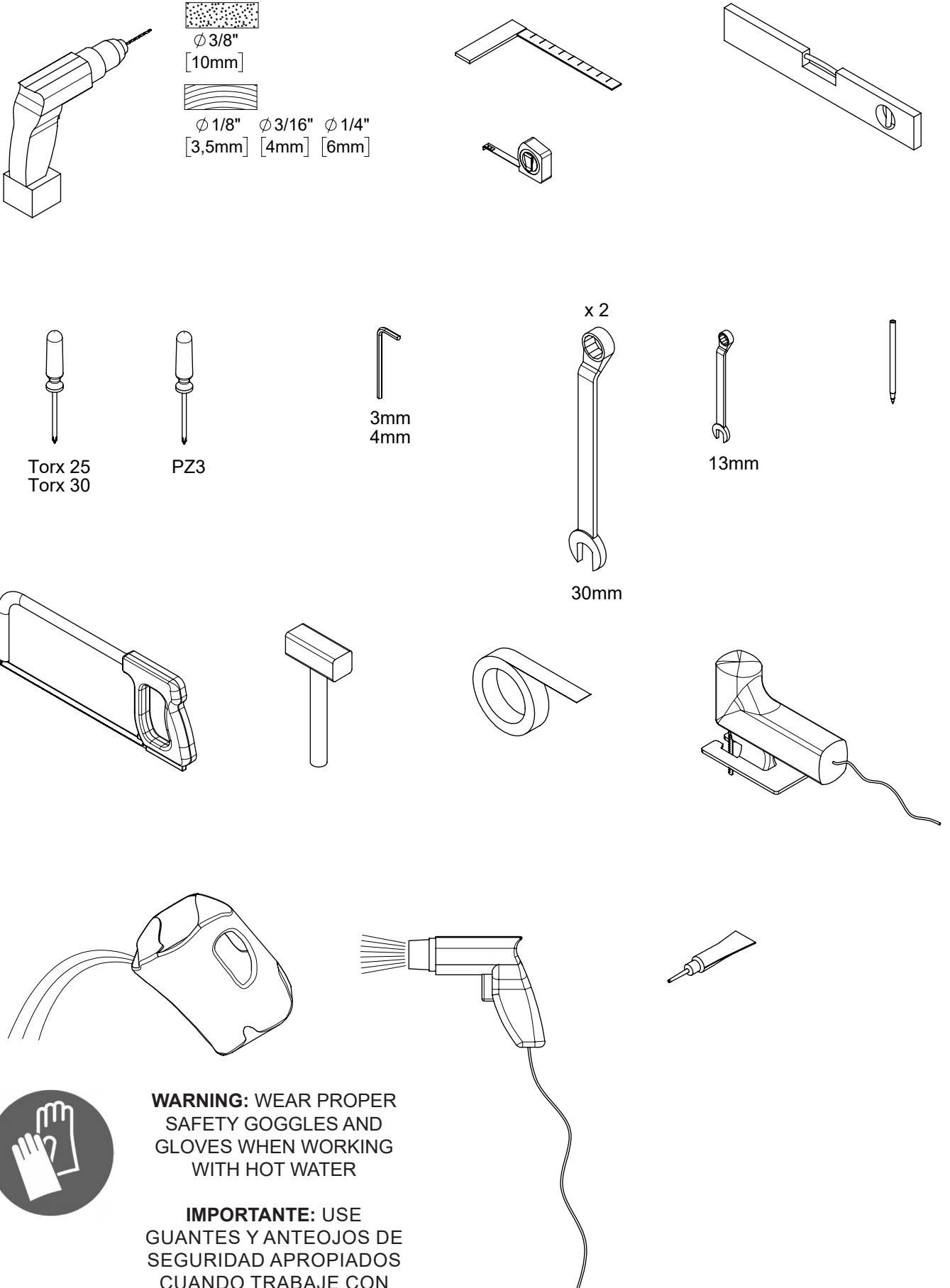

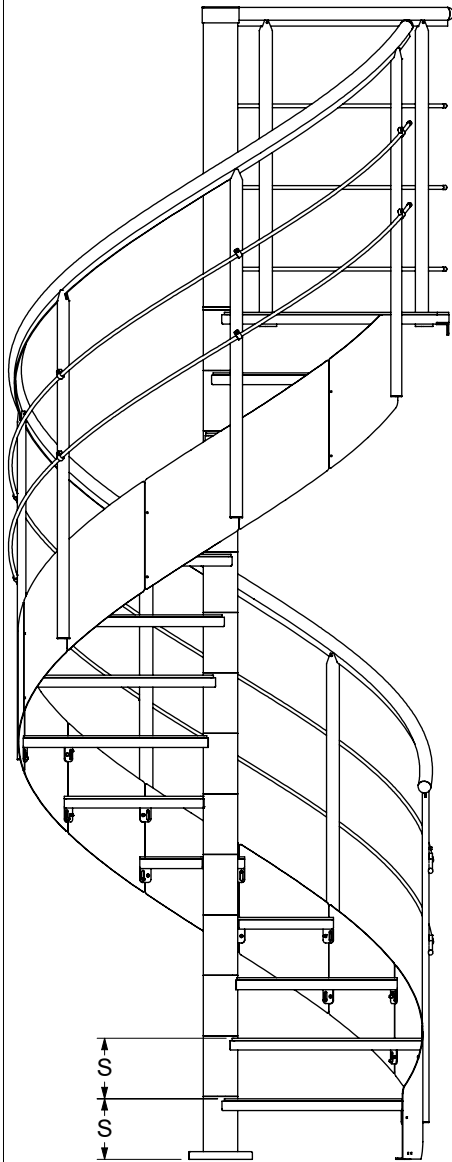

S =  
min 7 7/8" [200mm]  
max 8 7/8" [225mm]

7 7/8" [200mm]

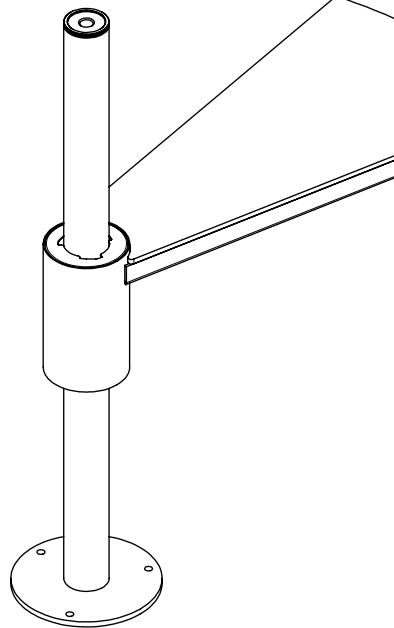

8 1/16" [205mm]

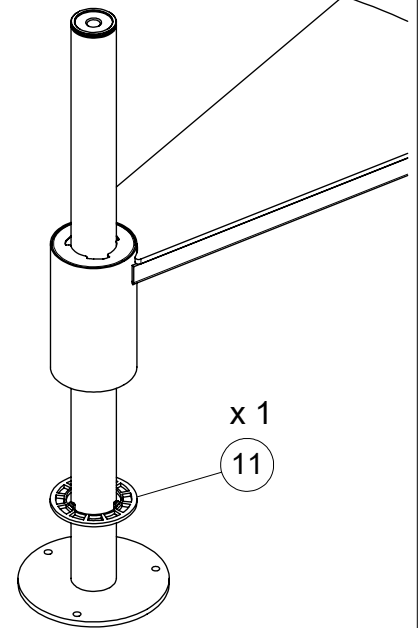

8 1/4" [210mm]

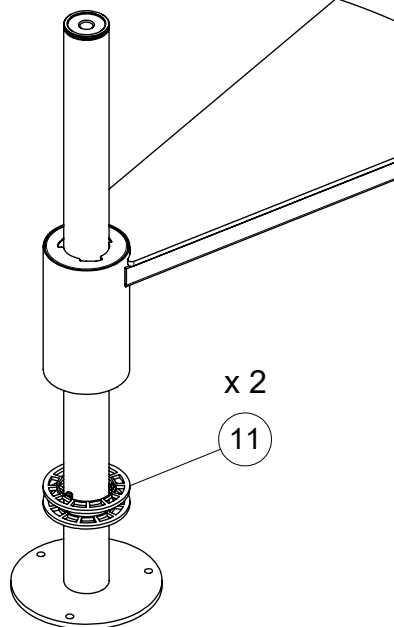

8 7/16" [215mm]

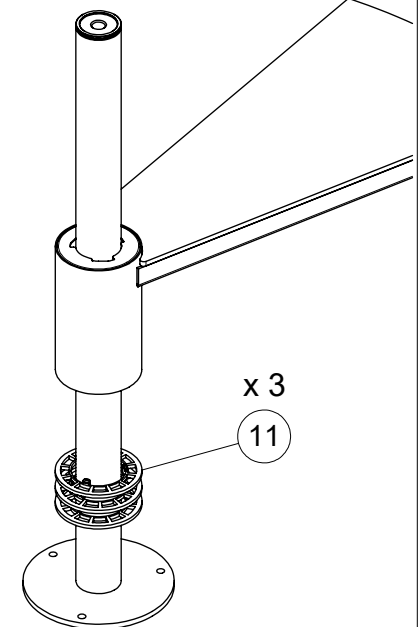

8 11/16" [220mm]

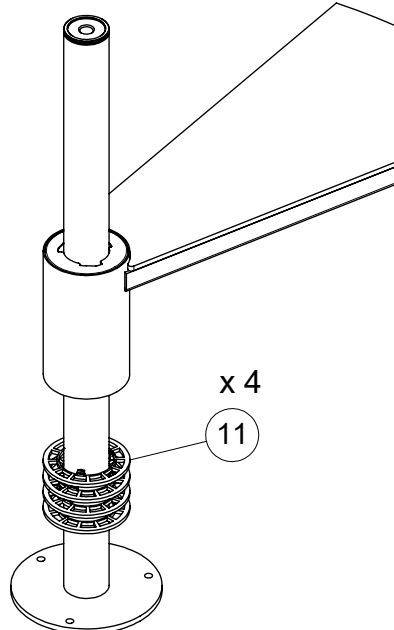

8 7/8" [225mm]

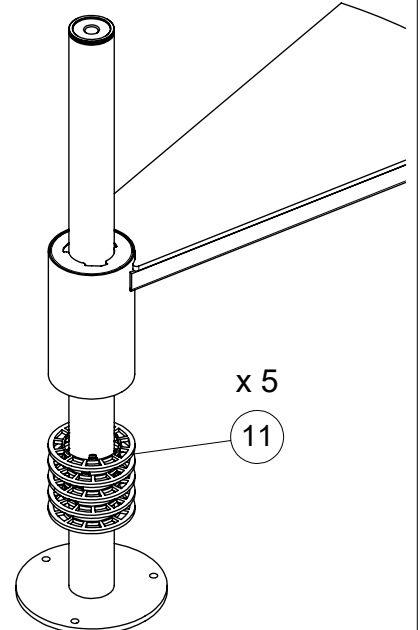



N  
0 - 5 pcs

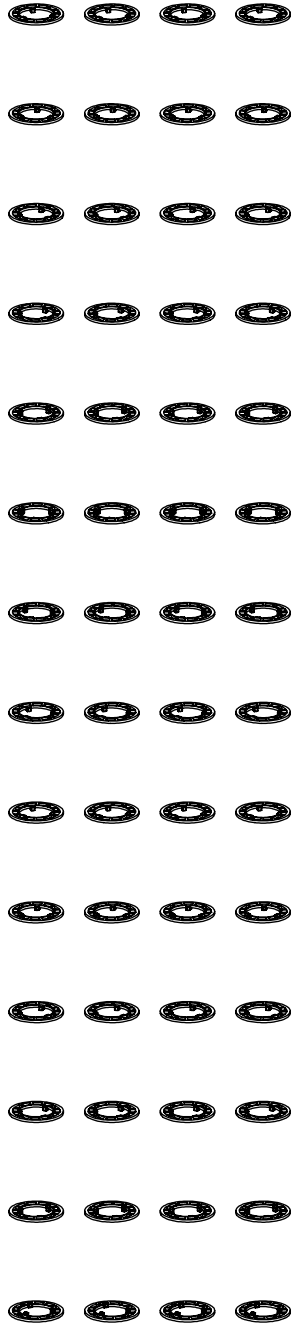

P  
+1 pcs



N x S

P

4 pcs x 13  
= 52 pcs

+ 5 pcs

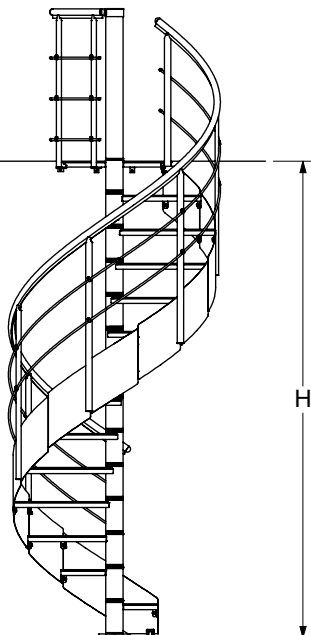
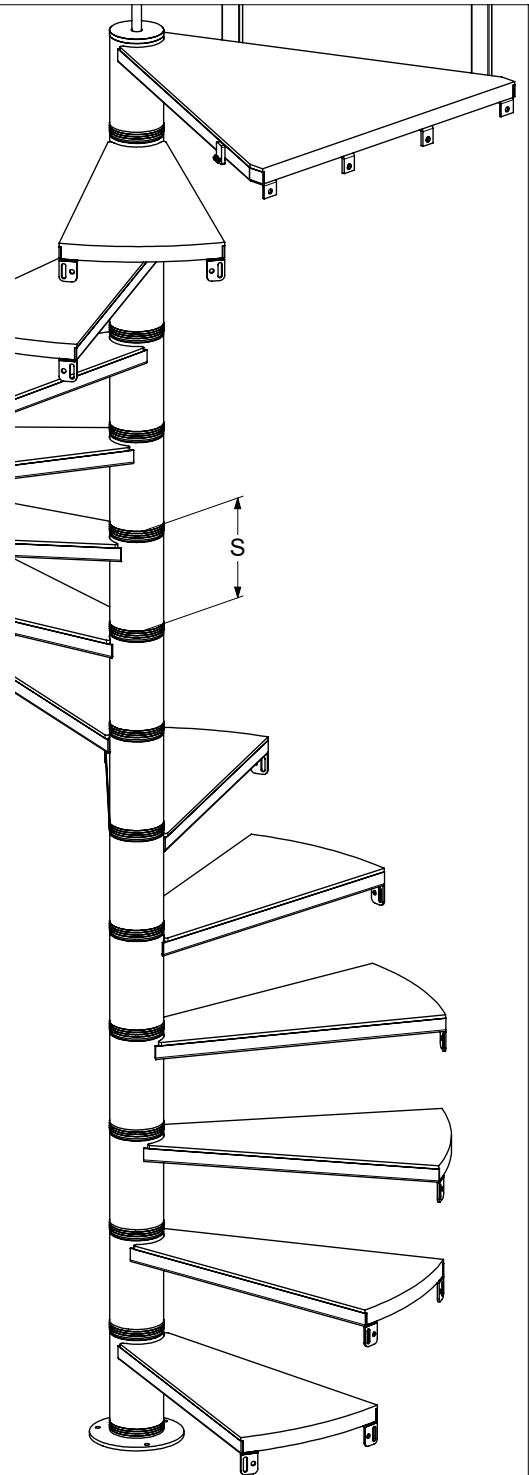

112	13/16	2865	4	1
113		2870	4	2
113	3/16	2875	4	3
113	3/8	2880	4	4
113	9/16	2885	4	5
113	3/4	2890	4	6
114		2895	4	7
114	3/16	2900	4	8
114	3/8	2905	4	9

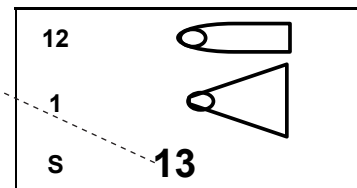

11				12				13				14												
1				1				1				1												
S				S				S				S												
H		N		P		H		N		P		H		N		P		H		N		P		
in	mm	pcs	pcs	in	mm	pcs	pcs	in	mm	pcs	pcs	in	mm	pcs	pcs	in	mm	pcs	pcs	in	mm	pcs	pcs	
94	1/2	2400	0	0	102	3/8	2600	3	4	102	3/8	2600	0	0	110	1/4	2800	3	1	110	1/4	2800	0	0
94	11/16	2405	0	1	102	9/16	2605	3	5	102	9/16	2605	0	1	110	7/16	2805	3	2	110	7/16	2805	0	1
94	7/8	2410	0	2	102	3/4	2610	3	6	102	3/4	2610	0	2	110	5/8	2810	3	3	110	3/4	2810	0	2
95	1/16	2415	0	3	102	15/16	2615	3	7	102	15/16	2615	0	3	110	13/16	2815	3	4	110	13/16	2815	0	3
95	1/4	2420	0	4	103	1/8	2620	3	8	103	1/8	2620	0	4	111		2820	3	5	111		2820	0	4
95	1/2	2425	0	5	103	3/8	2625	3	9	103	3/8	2625	0	5	111	1/4	2825	3	6	111	1/4	2825	0	5
95	11/16	2430	0	6	103	9/16	2630	3	10	103	9/16	2630	0	6	111	7/16	2830	3	7	111	7/16	2830	0	6
95	7/8	2435	0	7	103	3/4	2635	3	11	103	3/4	2635	0	7	111	5/8	2835	3	8	111	5/8	2835	0	7
96	1/16	2440	0	8	103	15/16	2640	4	0	103	15/16	2640	0	8	111	13/16	2840	3	9	111	13/16	2840	0	8
96	1/4	2445	0	9	104	1/8	2645	4	1	104	1/8	2645	0	9	112		2845	3	10	112		2845	0	9
96	7/16	2450	0	10	104	5/16	2650	4	2	104	5/16	2650	0	10	112	3/16	2850	3	11	112	3/16	2850	0	10
96	5/8	2455	0	11	104	1/2	2655	4	3	104	1/2	2655	0	11	112	3/8	2855	3	12	112	3/8	2855	0	11
96	7/8	2460	1	0	104	3/4	2660	4	4	104	3/4	2660	0	12	112	5/8	2860	4	0	112	5/8	2860	0	12
97	1/16	2465	1	1	104	15/16	2665	4	5	104	15/16	2665	1	0	112	13/16	2865	4	1	112	13/16	2865	0	13
97	1/4	2470	1	2	105	1/8	2670	4	6	105	1/8	2670	1	1	113		2870	4	2	113		2870	1	0
97	7/16	2475	1	3	105	5/16	2675	4	7	105	5/16	2675	1	2	113	3/16	2875	4	3	113	3/16	2875	1	1
97	5/8	2480	1	4	105	1/2	2680	4	8	105	1/2	2680	1	3	113	3/8	2880	4	4	113	3/8	2880	1	2
97	13/16	2485	1	5	105	11/16	2685	4	9	105	11/16	2685	1	4	113	9/16	2885	4	5	113	9/16	2885	1	3
98	1/16	2490	1	6	105	7/8	2690	4	10	105	7/8	2690	1	5	113	3/4	2890	4	6	113	3/4	2890	1	4
98	1/4	2495	1	7	106	1/8	2695	4	11	106	1/8	2695	1	6	114		2895	4	7	114		2895	1	5
98	7/16	2500	1	8	106	5/16	2700	5	0	106	5/16	2700	1	7	114	3/16	2900	4	8	114	3/16	2900	1	6
98	5/8	2505	1	9						106	1/2	2705	1	8	114	3/8	2905	4	9	114	3/8	2905	1	7
98	13/16	2510	1	10						106	11/16	2710	1	9	114	9/16	2910	4	10	114	9/16	2910	1	8
99		2515	1	11						106	7/8	2715	1	10	114	3/4	2915	4	11	114	3/4	2915	1	9
99	3/16	2520	2	0						107	1/16	2720	1	11	114	15/16	2920	4	12	114	15/16	2920	1	10
99	7/16	2525	2	1						107	5/16	2725	1	12	115	3/16	2925	5	0	115	3/16	2925	1	11
99	5/8	2530	2	2						107	1/2	2730	2	0						115	3/8	2930	1	12
99	13/16	2535	2	3						107	11/16	2735	2	1						115	9/16	2935	1	13
100		2540	2	4						107	7/8	2740	2	2						115	3/4	2940	2	0
100	3/16	2545	2	5						108	1/16	2745	2	3						115	15/16	2945	2	1
100	3/8	2550	2	6						108	1/4	2750	2	4						116	1/8	2950	2	2
100	9/16	2555	2	7						108	7/16	2755	2	5						116	5/16	2955	2	3
100	13/16	2560	2	8						108	11/16	2760	2	6						116	9/16	2960	2	4
101		2565	2	9						108	7/8	2765	2	7						116	3/4	2965	2	5
101	3/16	2570	2	10						109	1/16	2770	2	8						116	15/16	2970	2	6
101	3/8	2575	2	11						109	1/4	2775	2	9						117	1/8	2975	2	7
101	9/16	2580	3	0						109	7/16	2780	2	10						117	5/16	2980	2	8
101	3/4	2585	3	1						109	5/8	2785	2	11						117	1/2	2985	2	9
101	15/16	2590	3	2						109	13/16	2790	2	12						117	11/16	2990	2	10
102	3/16	2595	3	3						110	1/16	2795	3	0						117	15/16	2995	2	11
																				118	1/8	3000	2	12
																				118	5/16	3005	2	13
																				118	1/2	3010	3	0





**L**

Left turn staircase  
Escalera a la izquierda

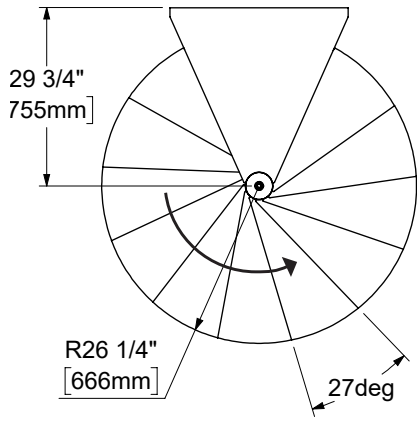

**R**

Right turn staircase  
Escalera a la derecha

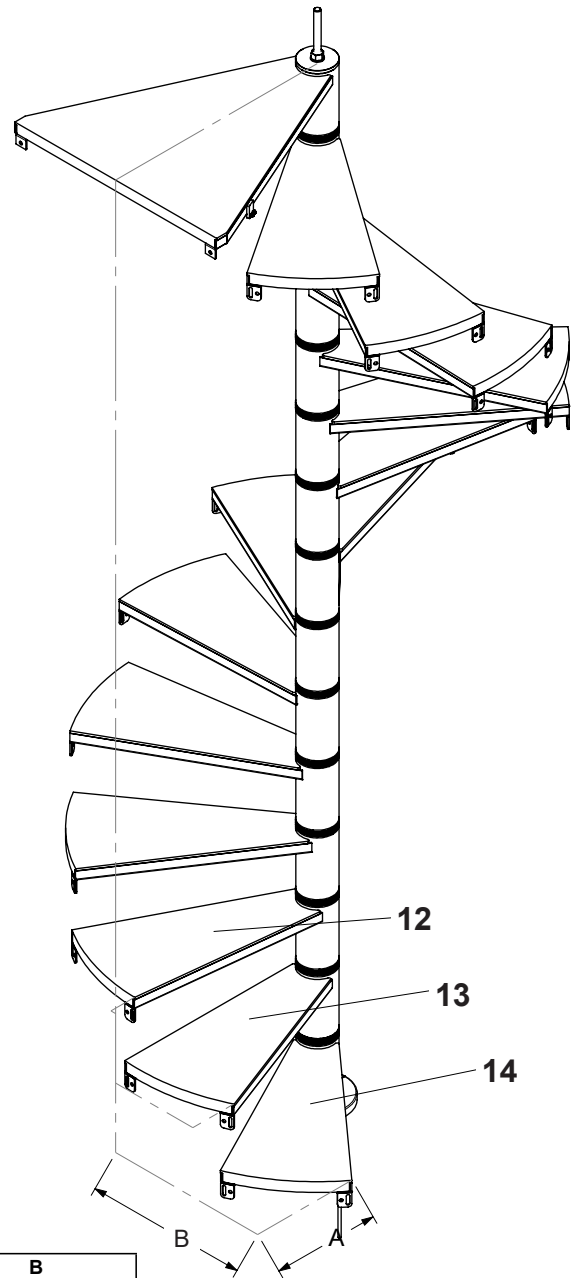
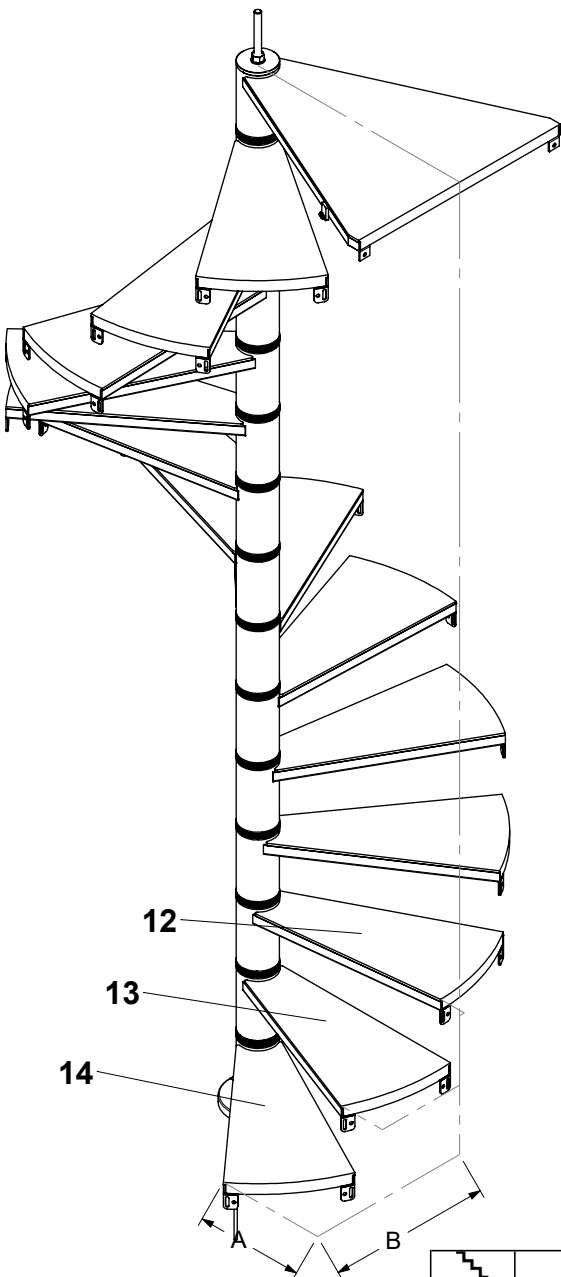
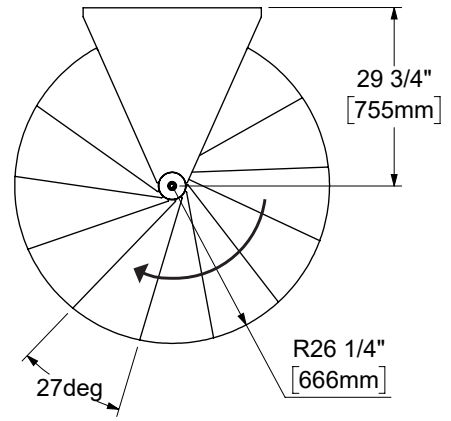

	A		B	
	in	mm	in	mm
12	3 1/2	88	- 11/16	-18
13	6 1/16	154	11 1/4	289
14	13 3/4	352	20 15/16	531



L

R

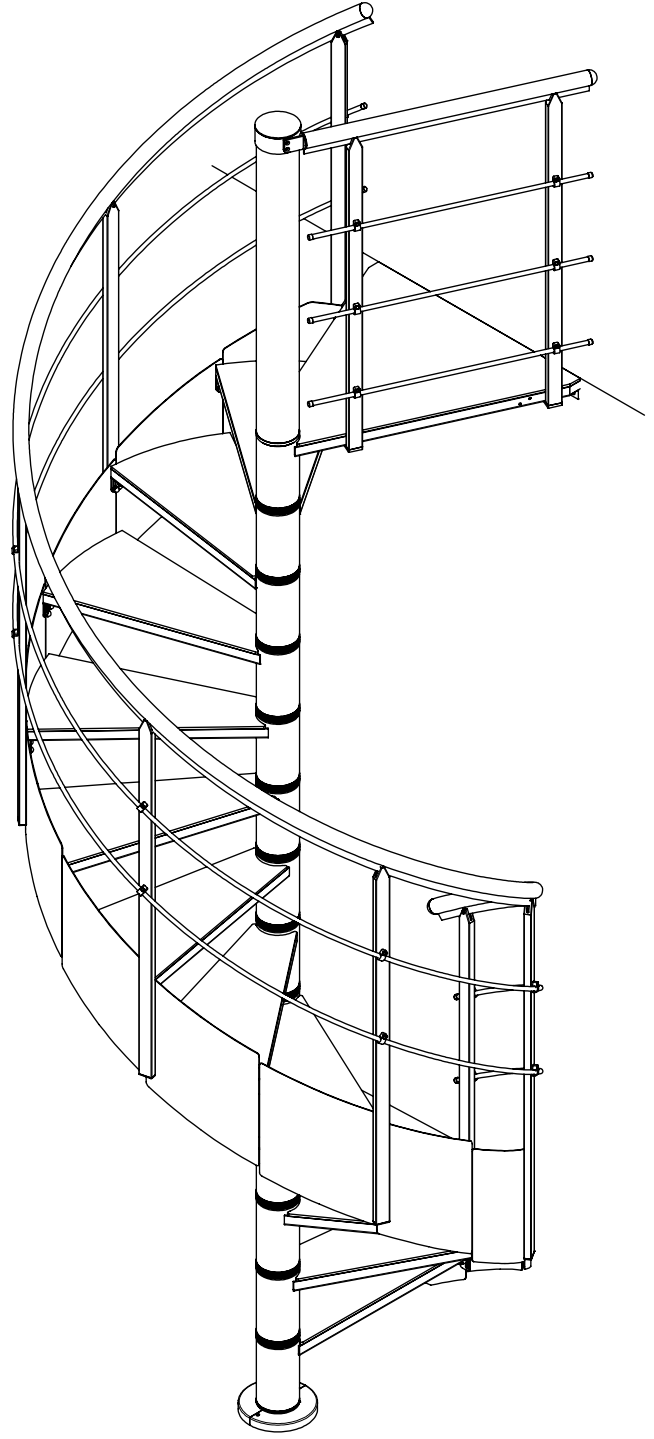
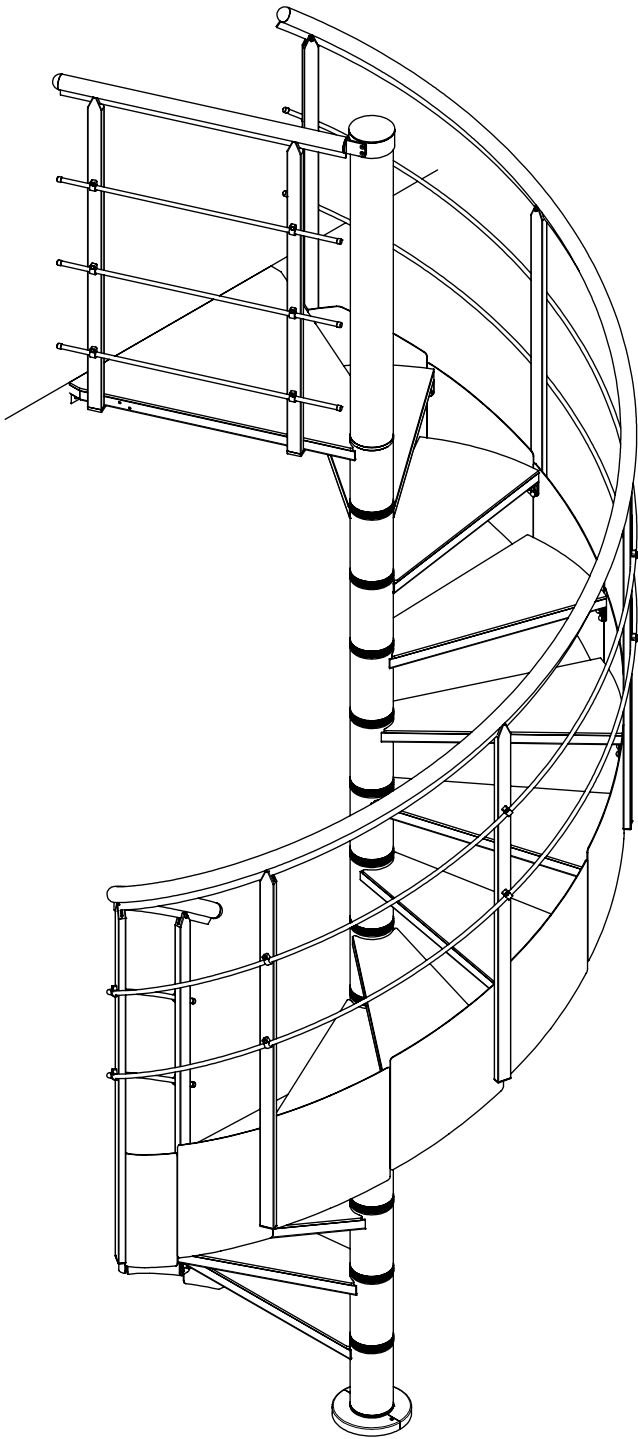

Left turn staircase  
Escalera a la izquierda

Right turn staircase  
Escalera a la derecha

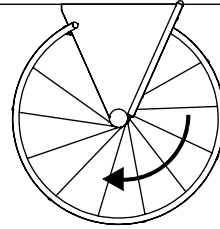
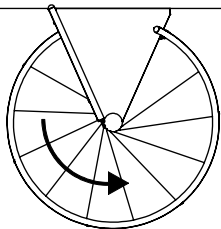

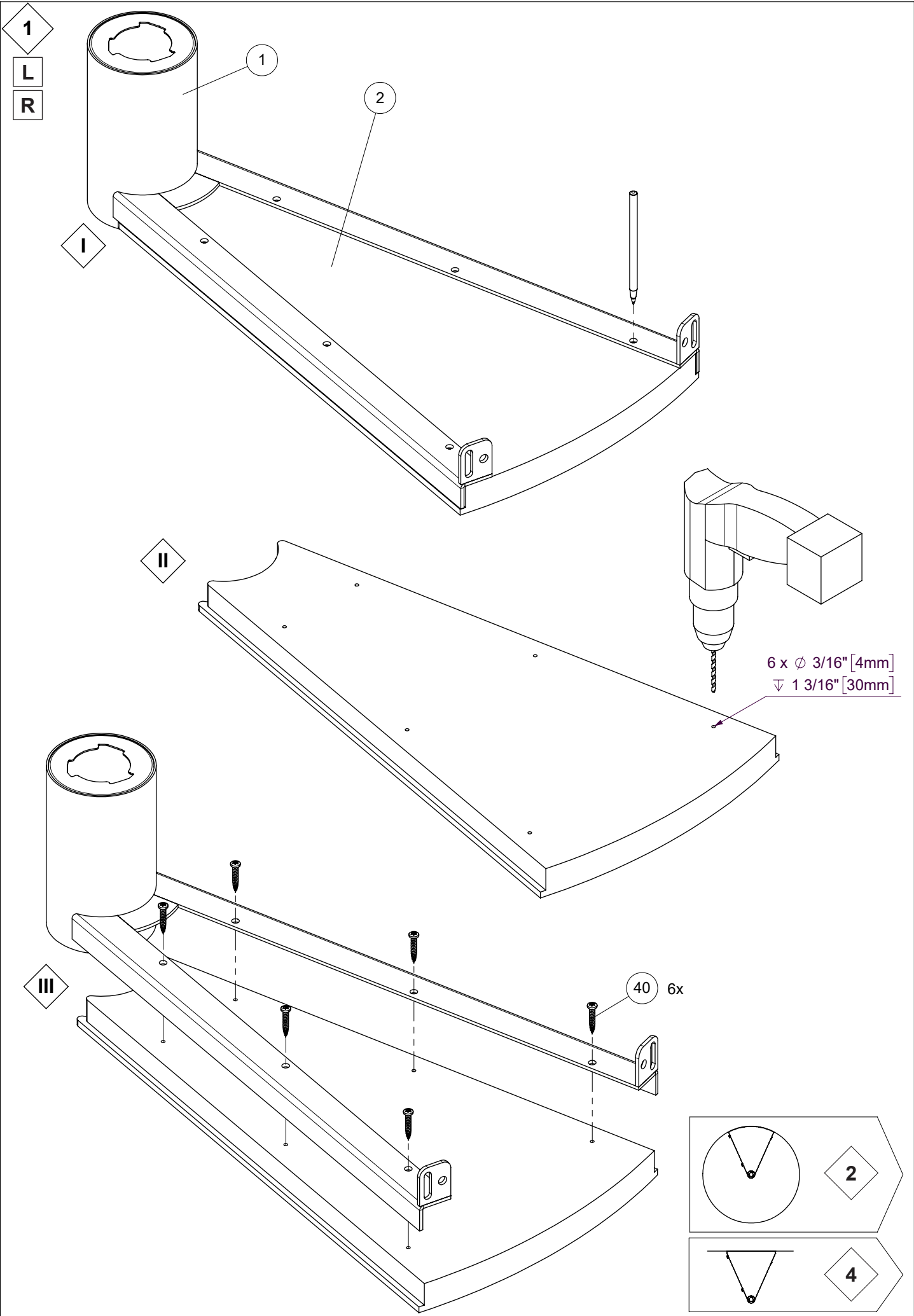

2

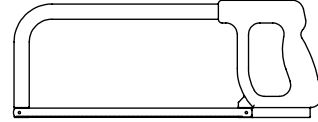
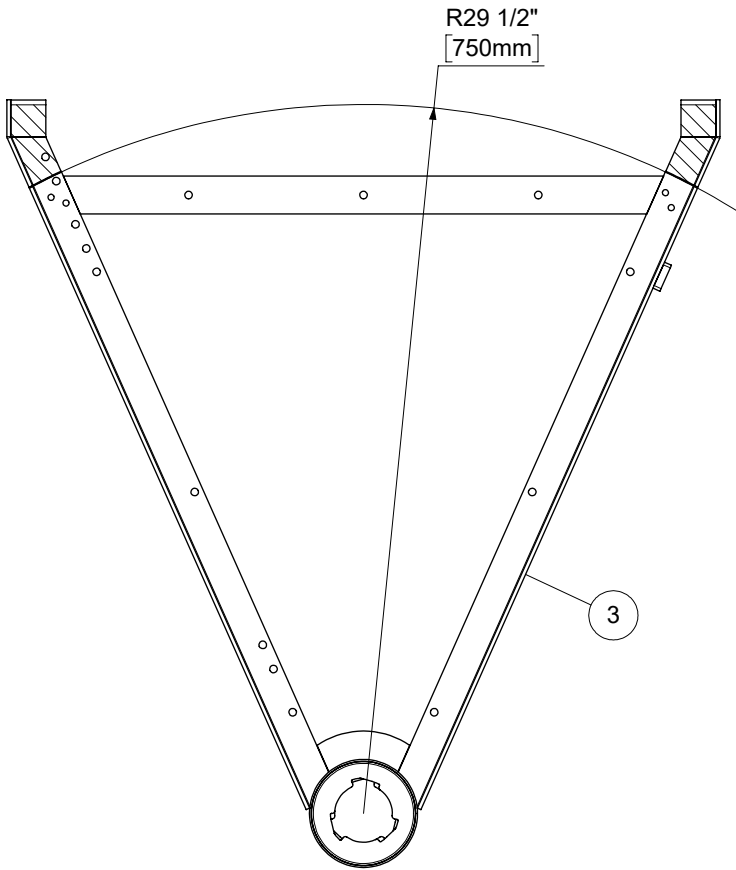
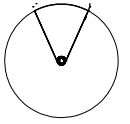

3

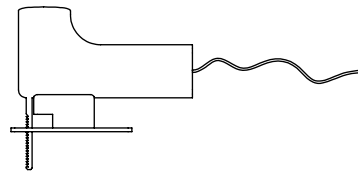
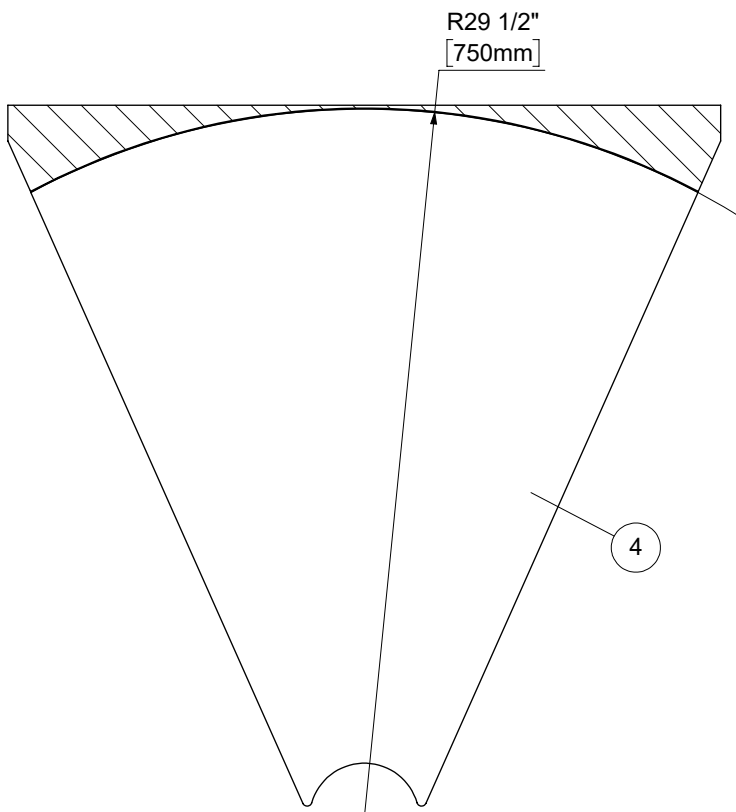
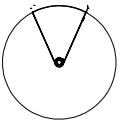

4

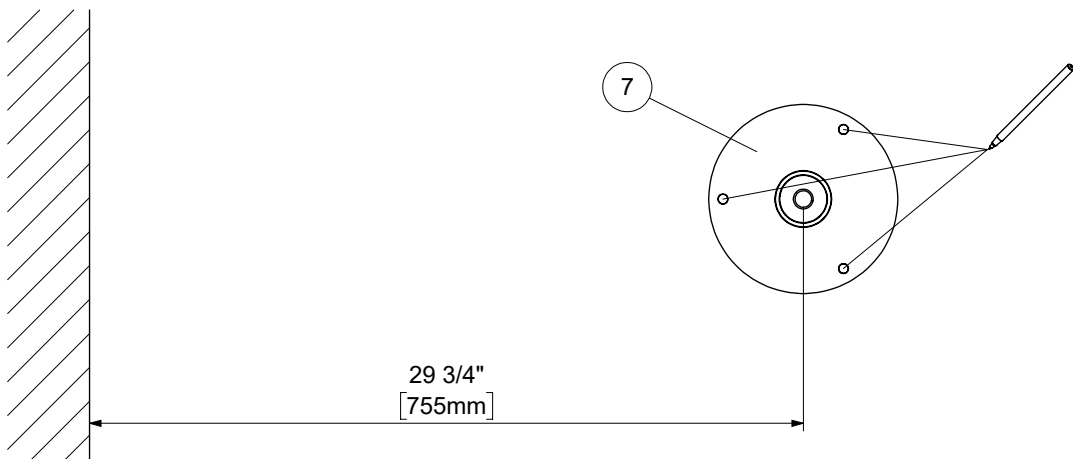
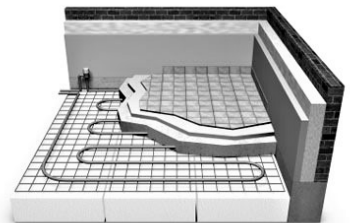
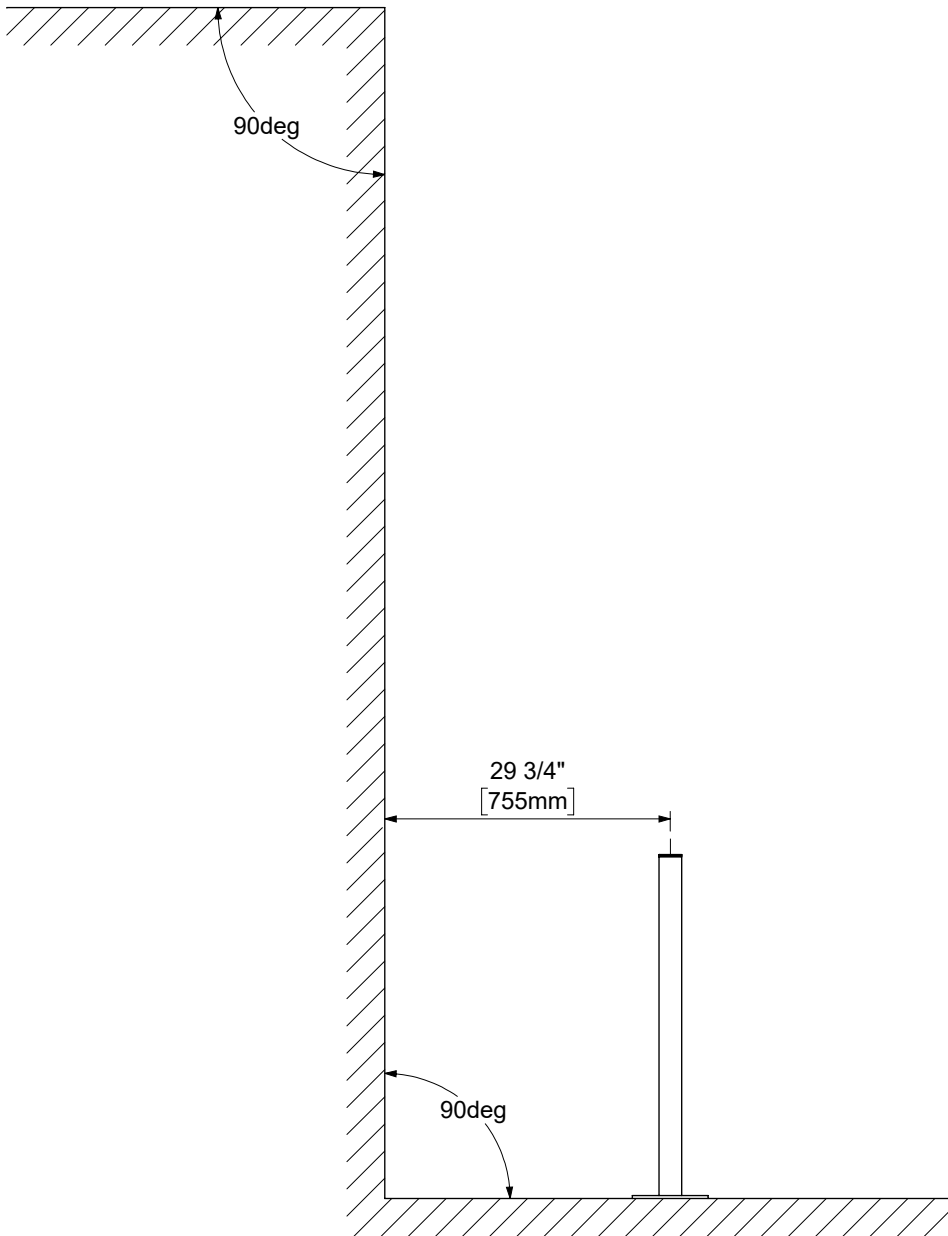

5

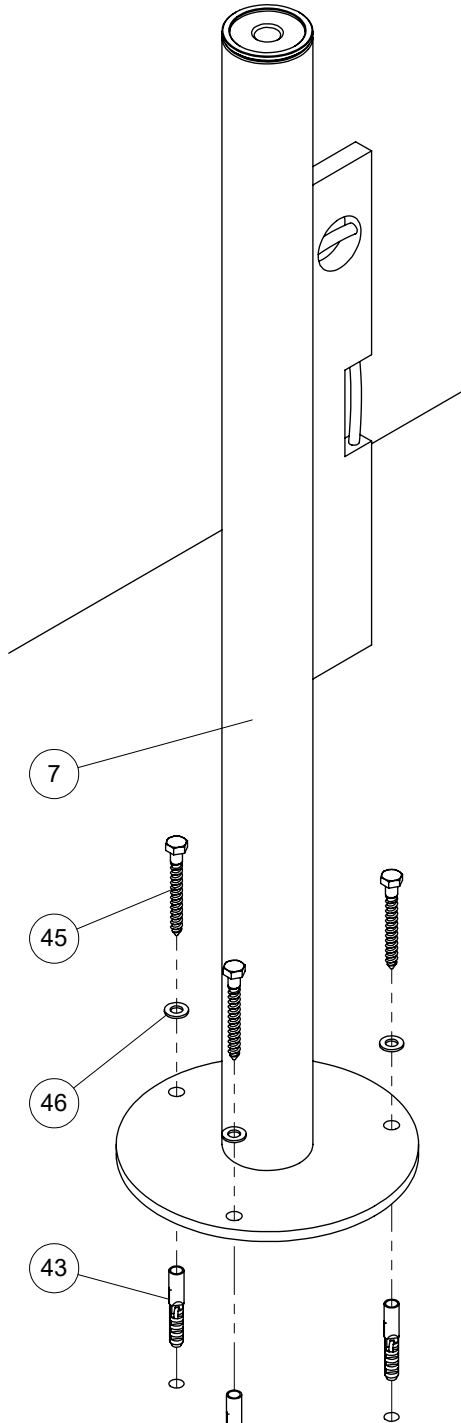

3 x  $\varnothing$  3/8" [10mm]  
 $\nabla$  2 3/4" [70mm]

3 x  $\varnothing$  1/4" [6mm]  
 $\nabla$  2 3/4" [70mm]

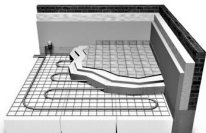
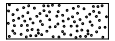
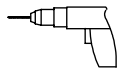

6

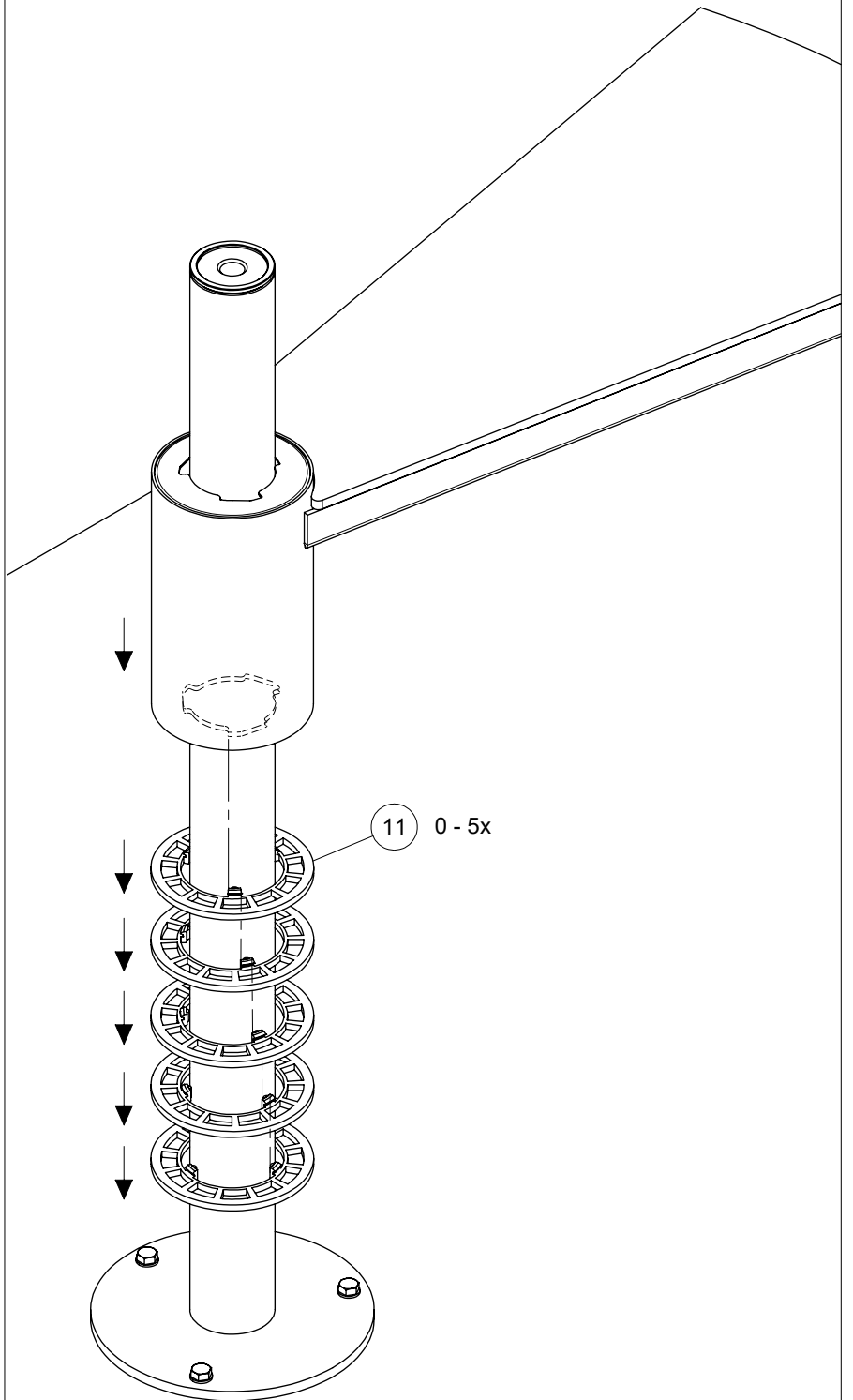

11 0 - 5x

7

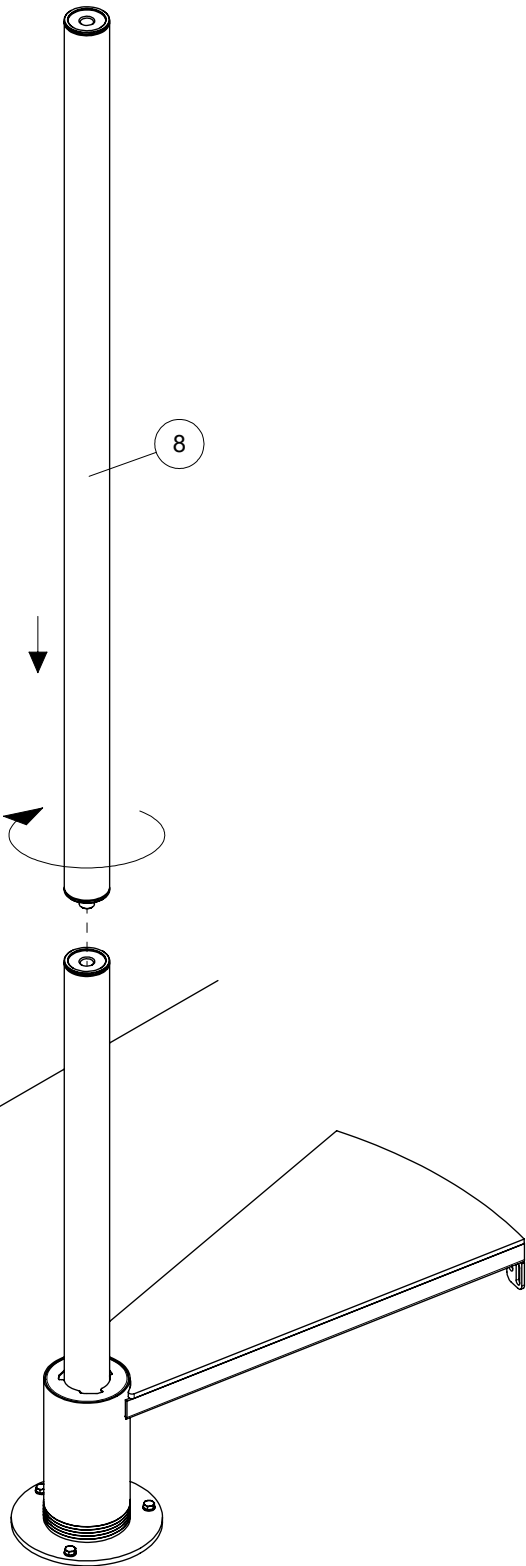

8

$$T = H - 91 \frac{5}{16}'' [2320\text{mm}]$$

$$LX = T - 3 \frac{1}{8}'' [80\text{mm}]$$

$$LY = T + 8 \frac{1}{4}'' [210\text{mm}]$$

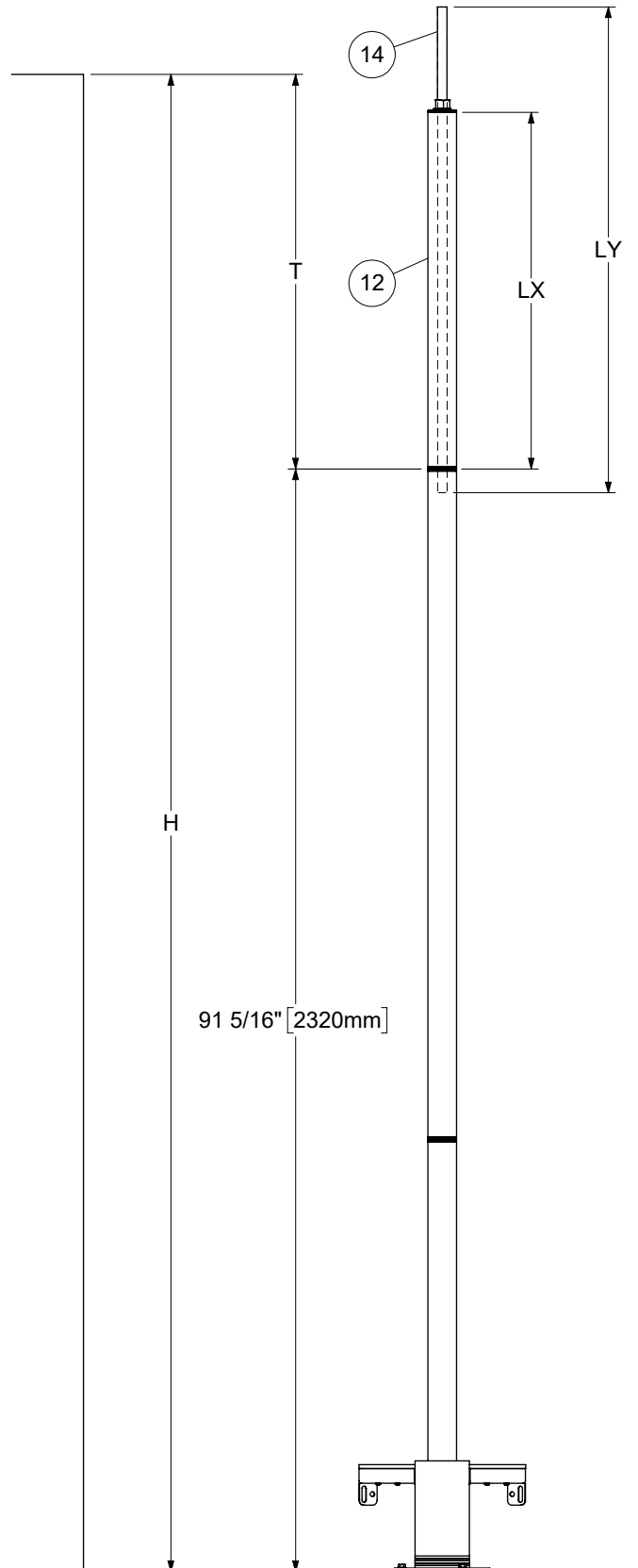

9

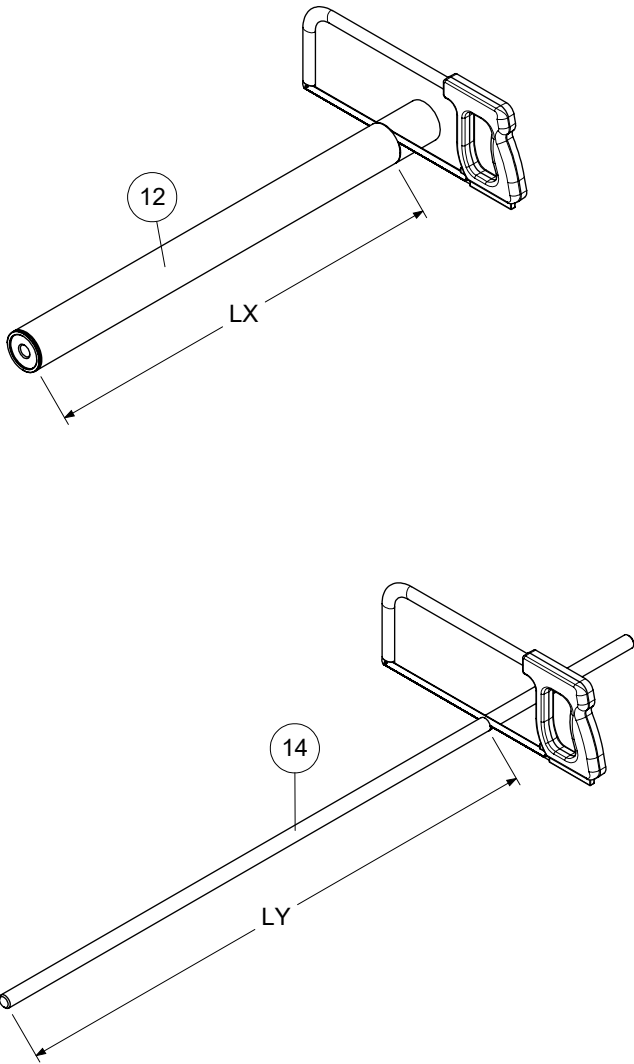

10

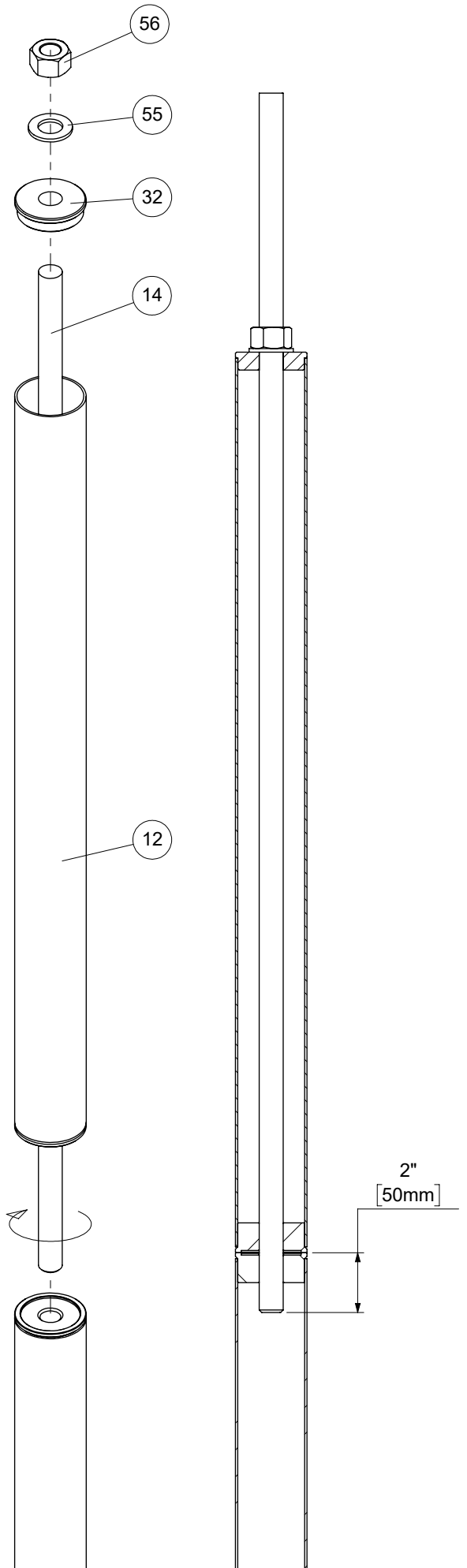



11

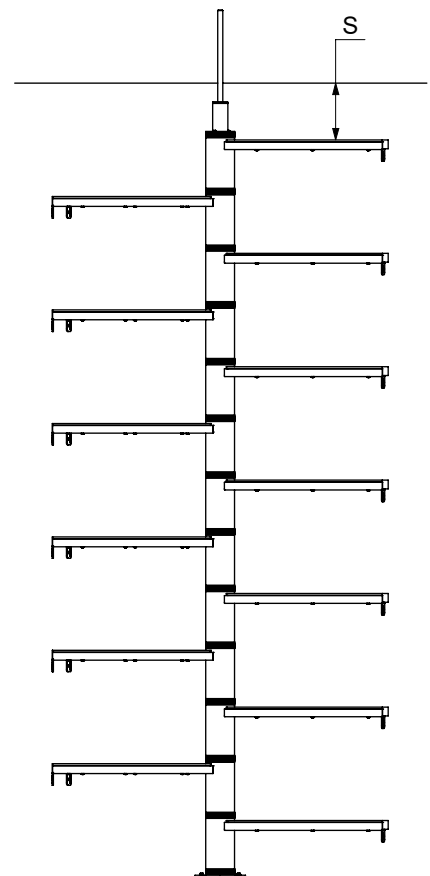
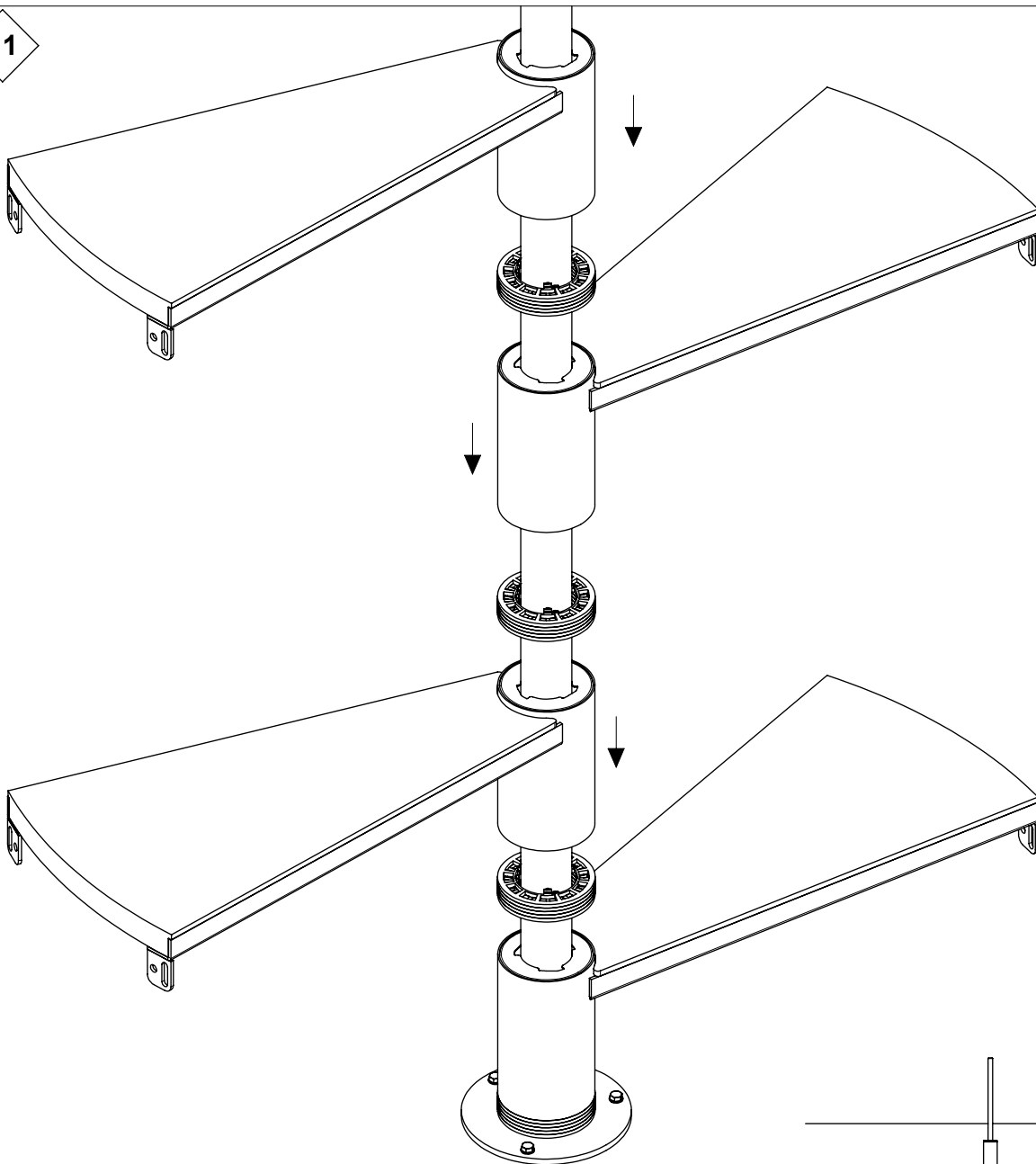

12

I

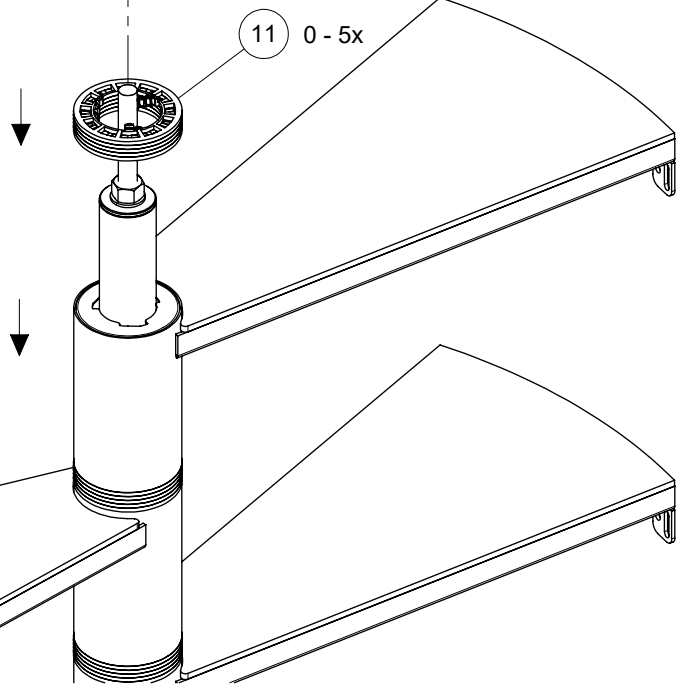
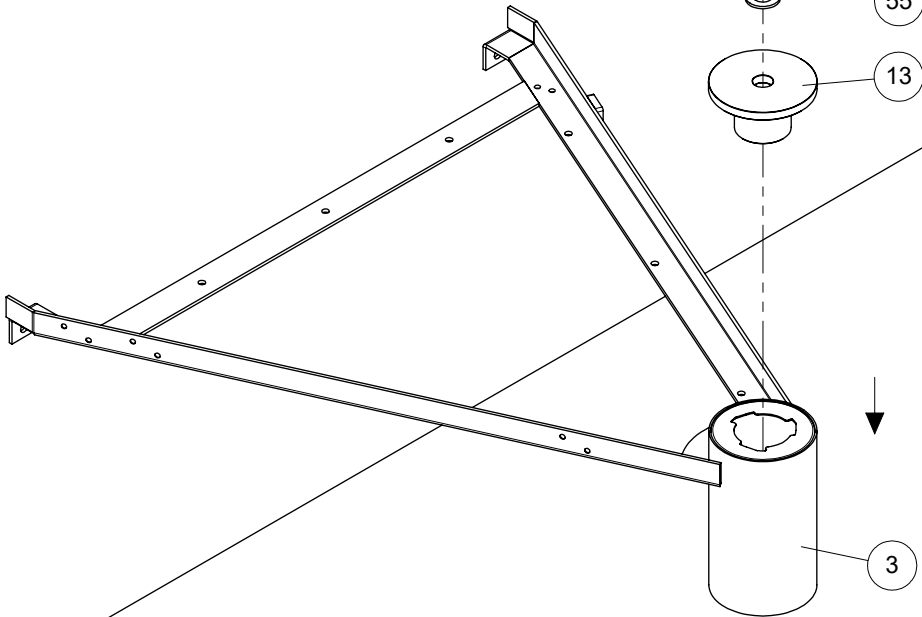
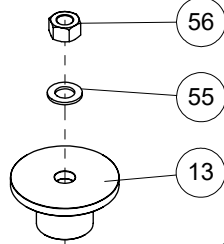

II

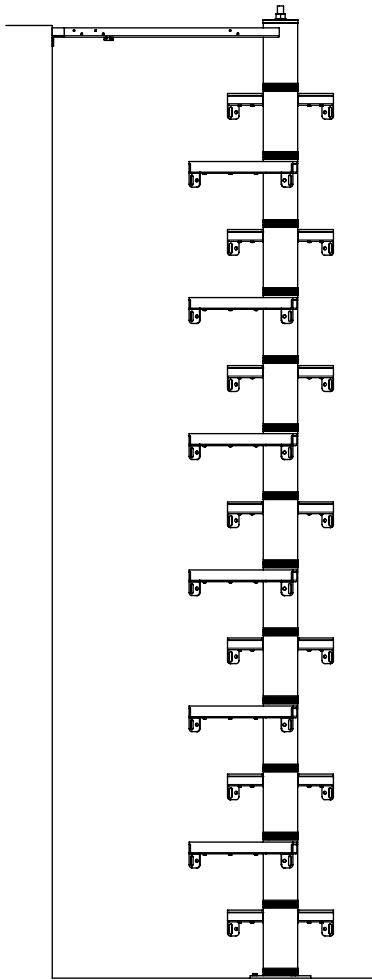
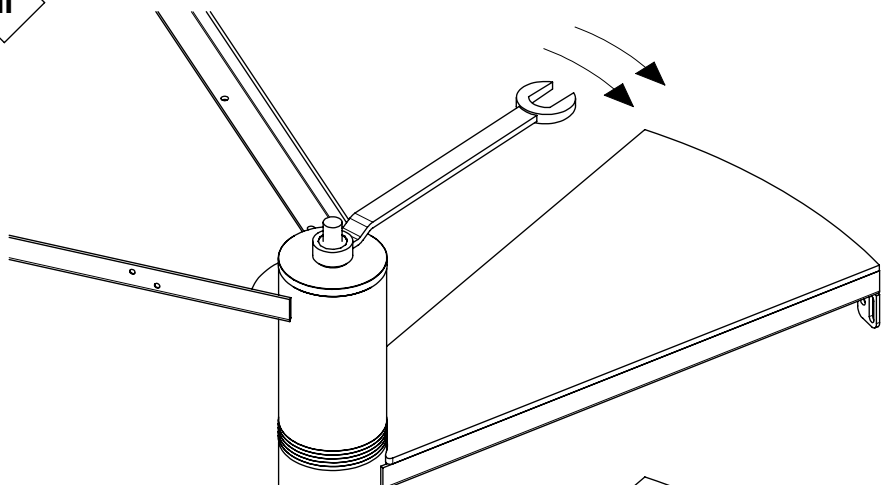

13

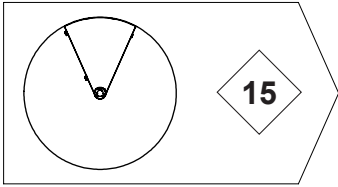

2 1/4" [57mm]

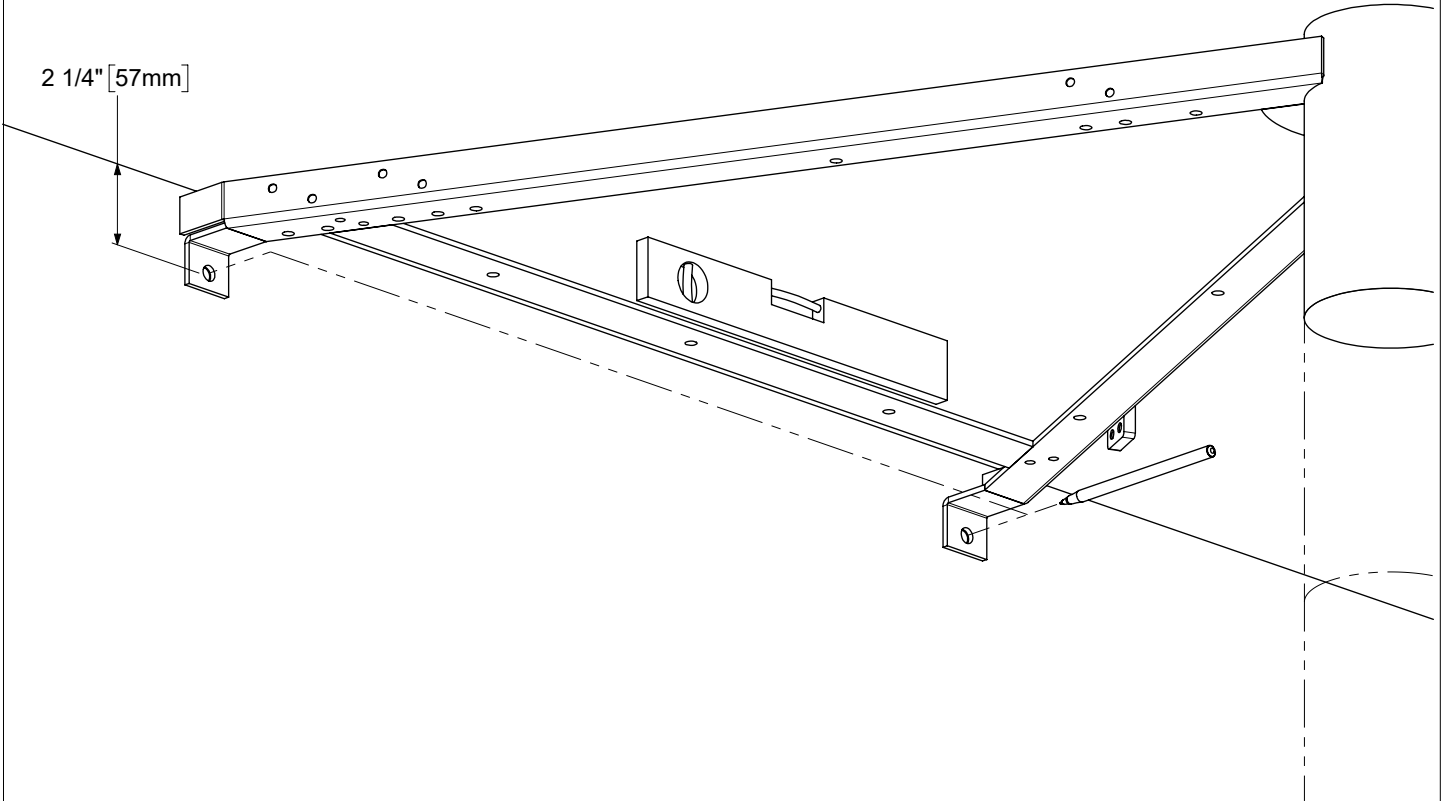

14

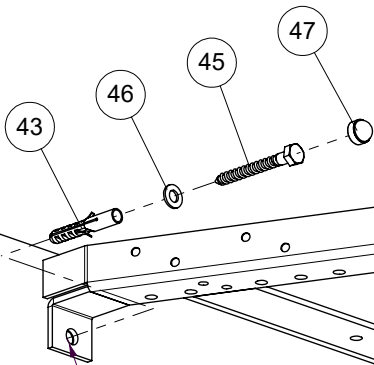

- 2 x  $\varnothing$  3/8" [10mm]
- ▽ 2 3/4" [70mm]
- 2 x  $\varnothing$  1/4" [6mm]
- ▽ 2 3/4" [70mm]

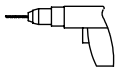

17

15

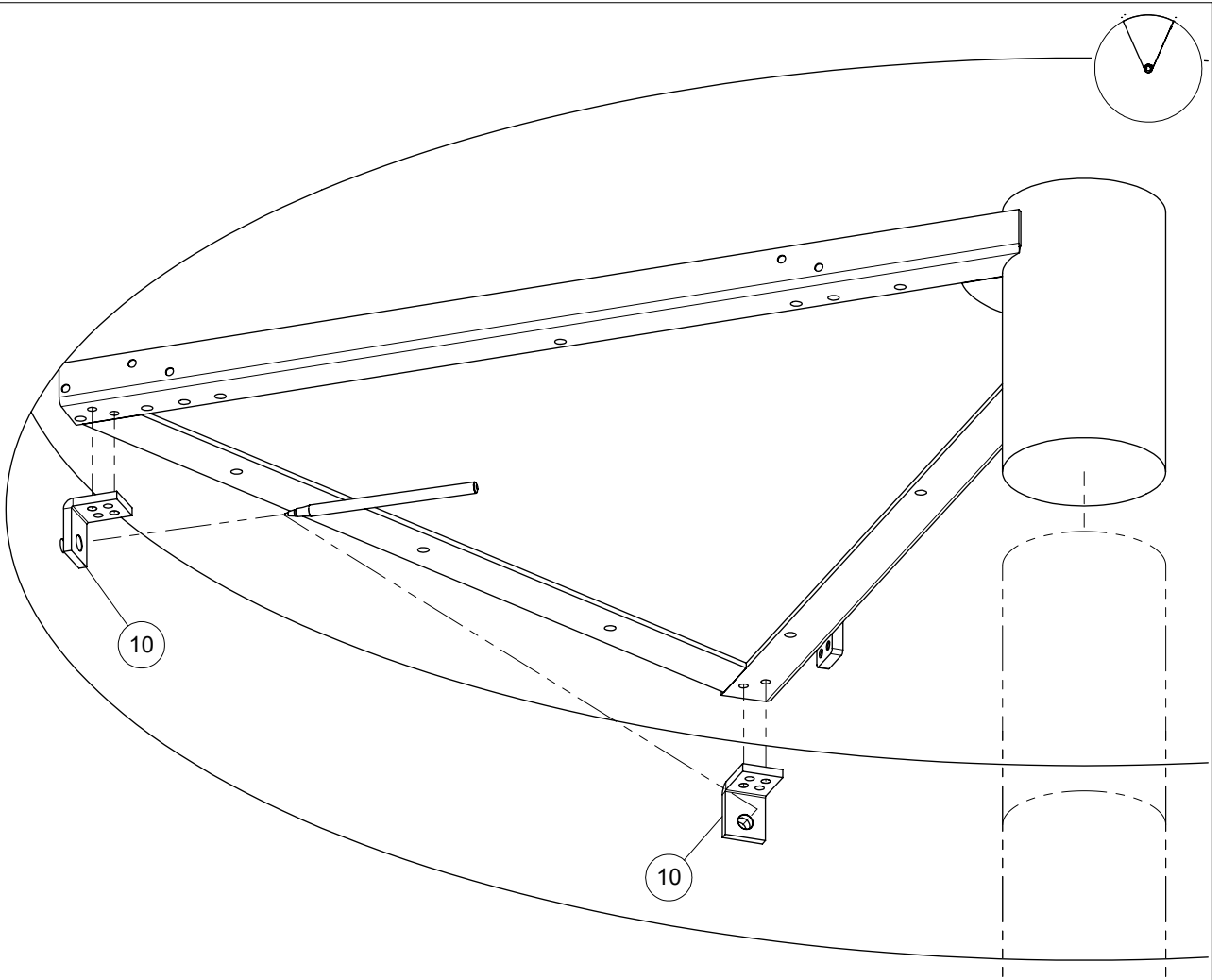

16

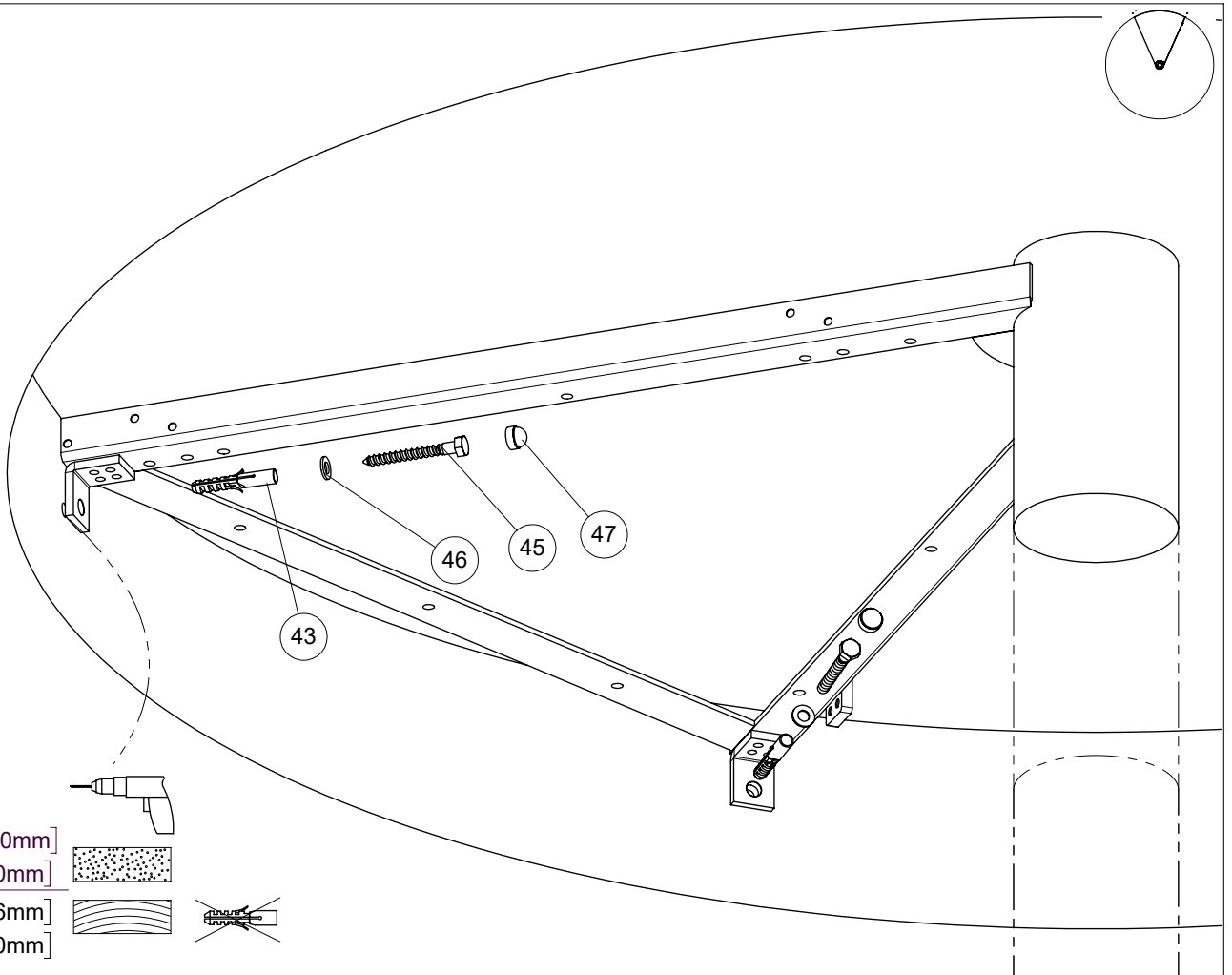

2 x  $\varnothing$  3/8" [10mm]  
 $\nabla$  2 3/4" [70mm]

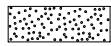

2 x  $\varnothing$  1/4" [6mm]  
 $\nabla$  2 3/4" [70mm]



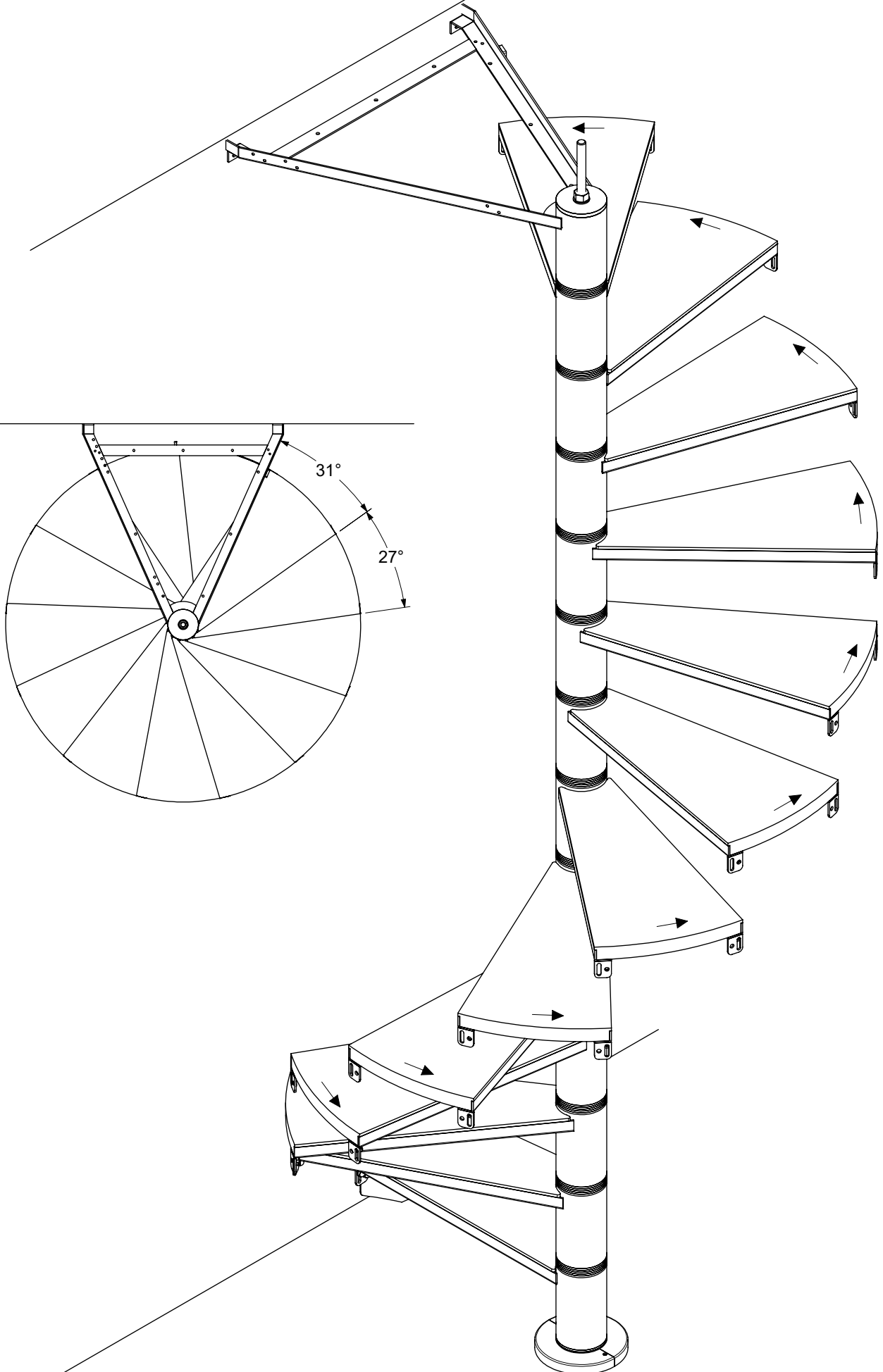

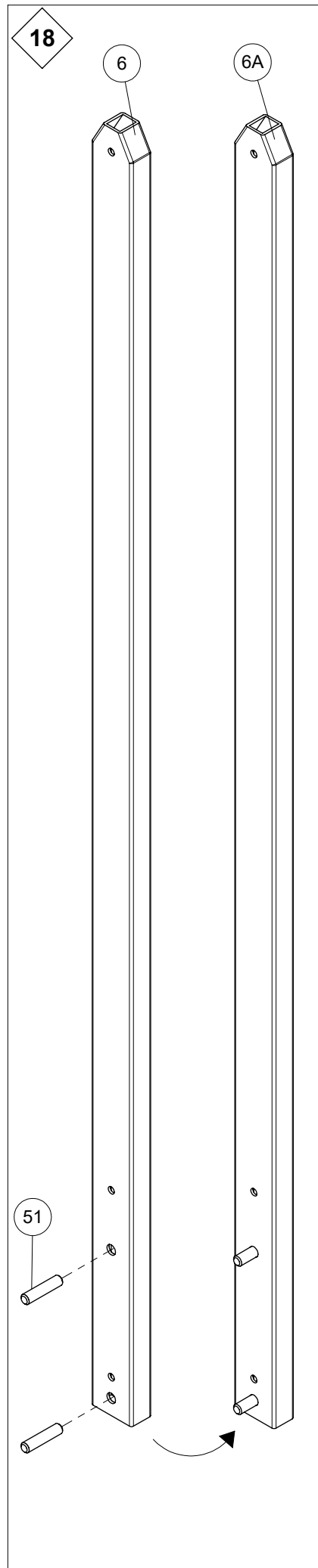

S:14

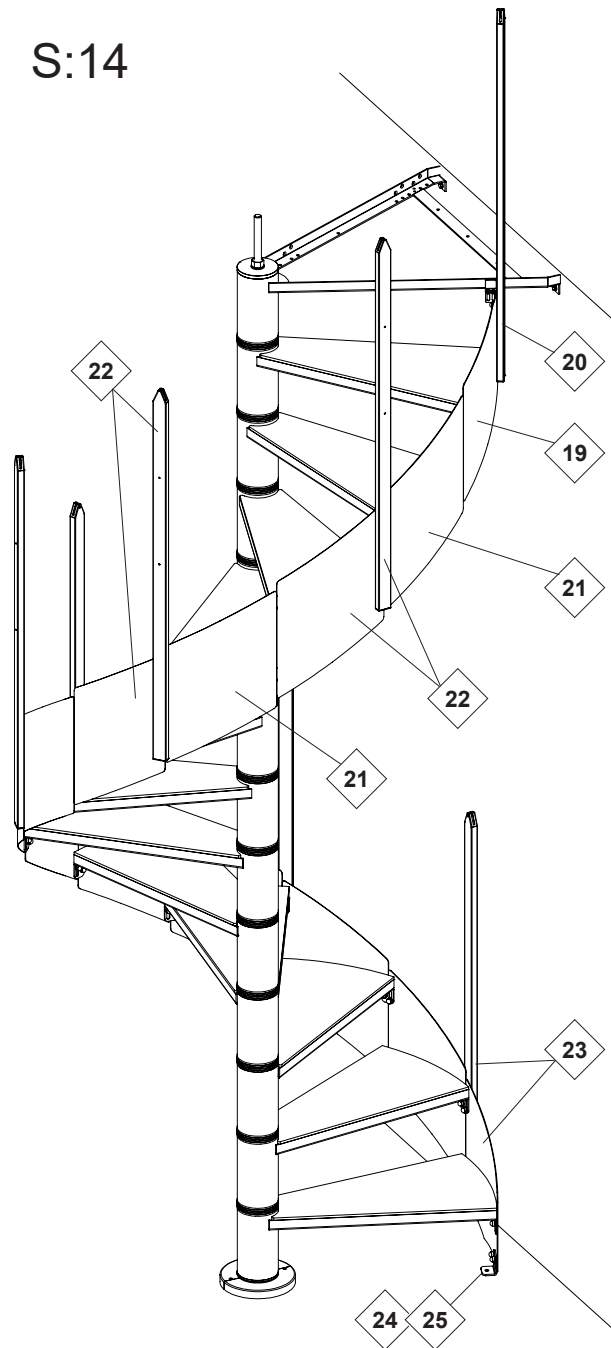

S: 13

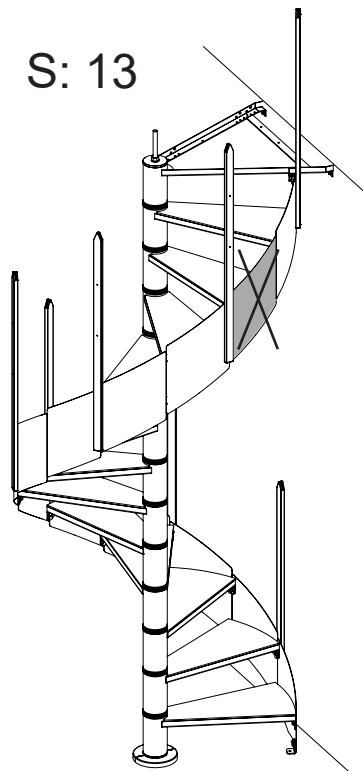

S: 12

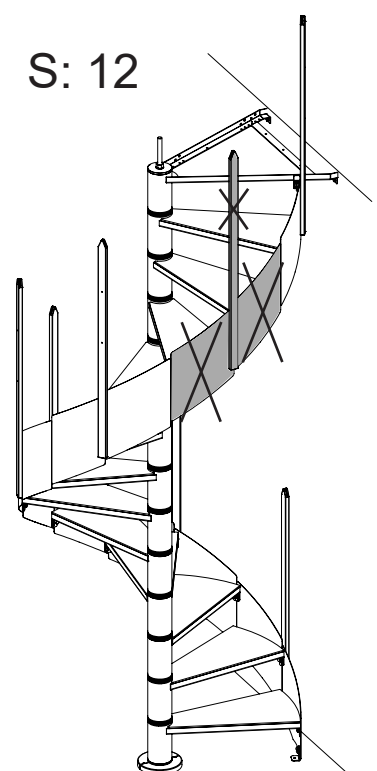

19

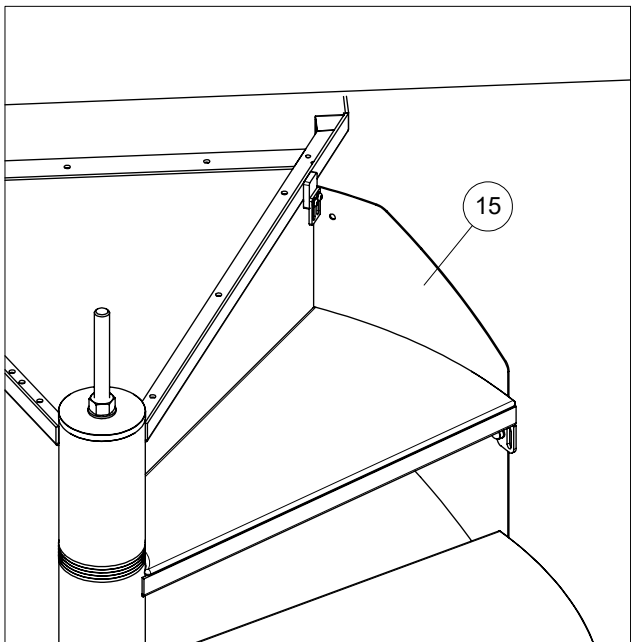
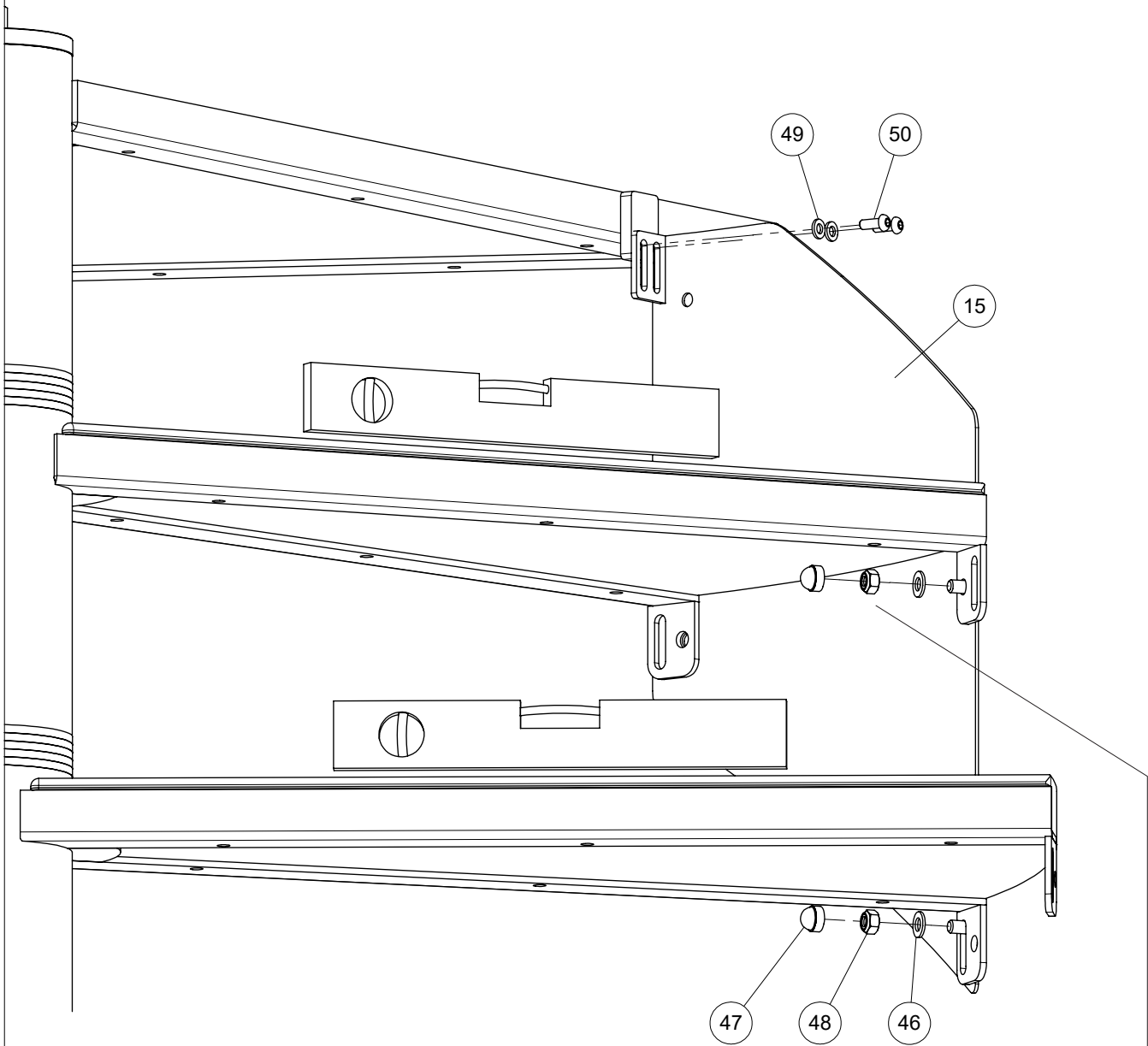

20



Max  
7.37lbf  
[10 Nm]

6A

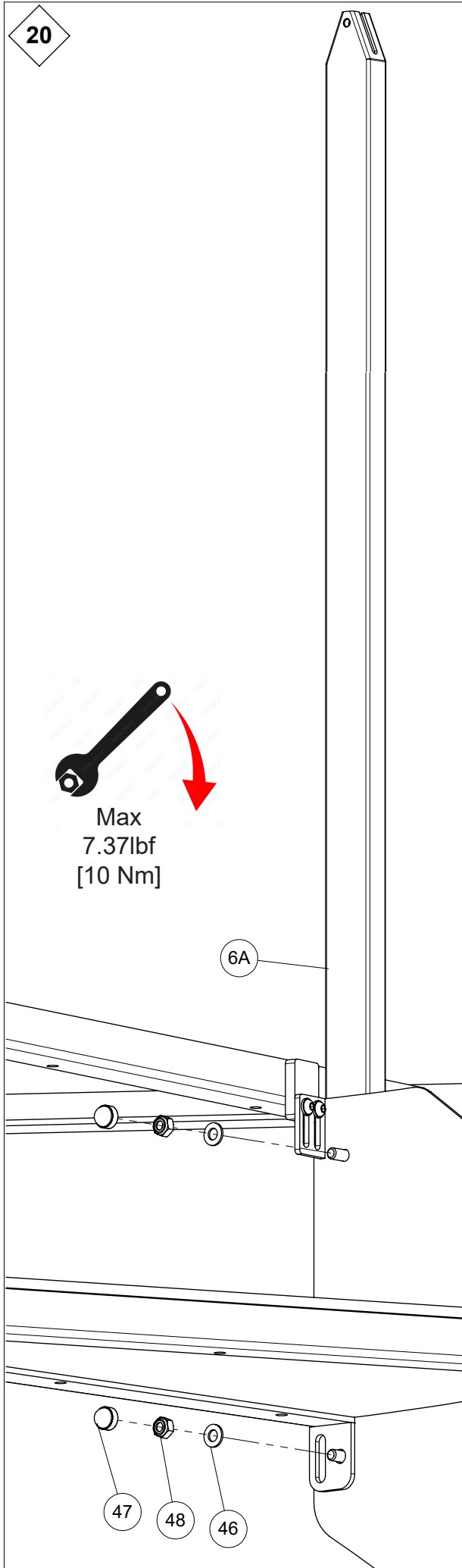

21

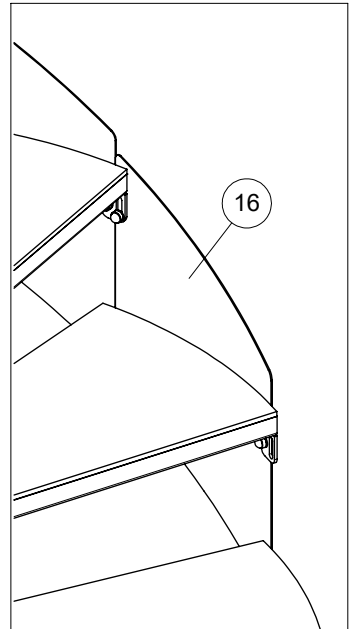

16

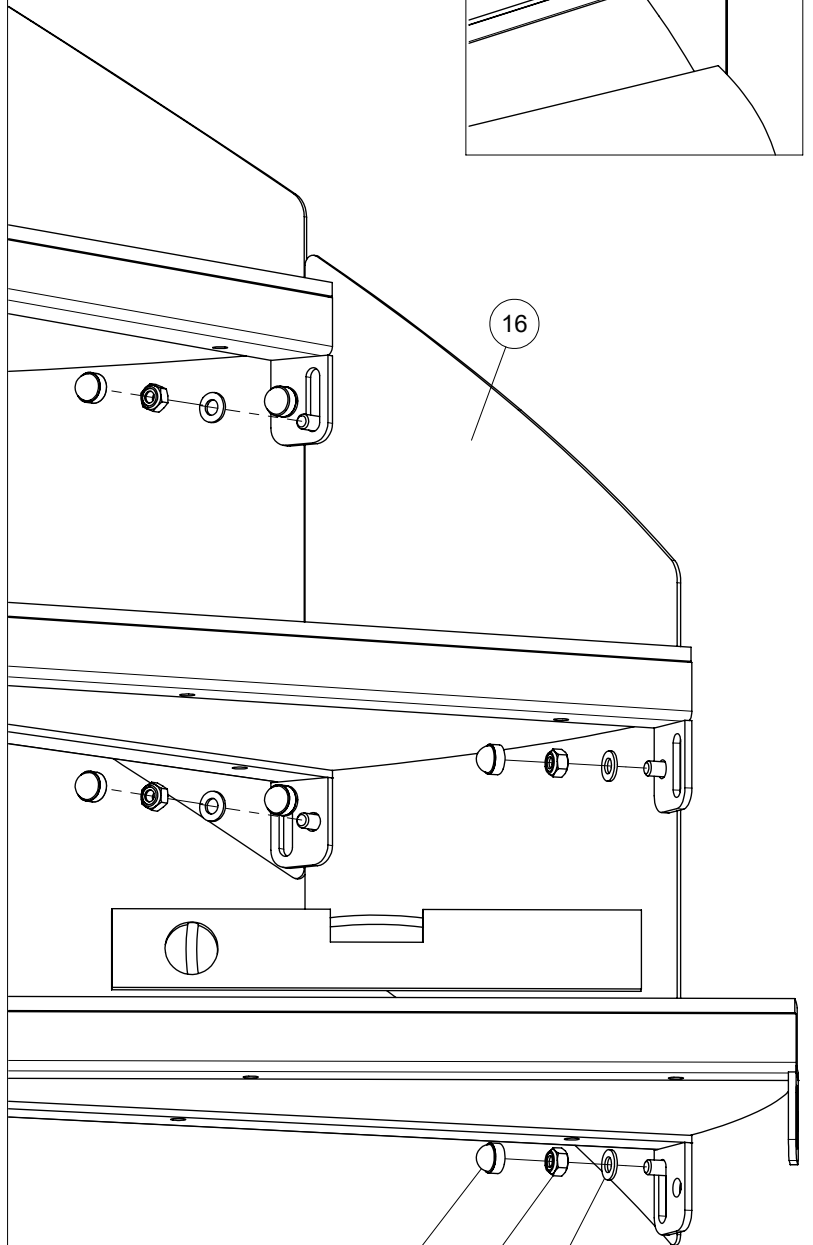

47

48

46



Max  
7.37lbf  
[10 Nm]

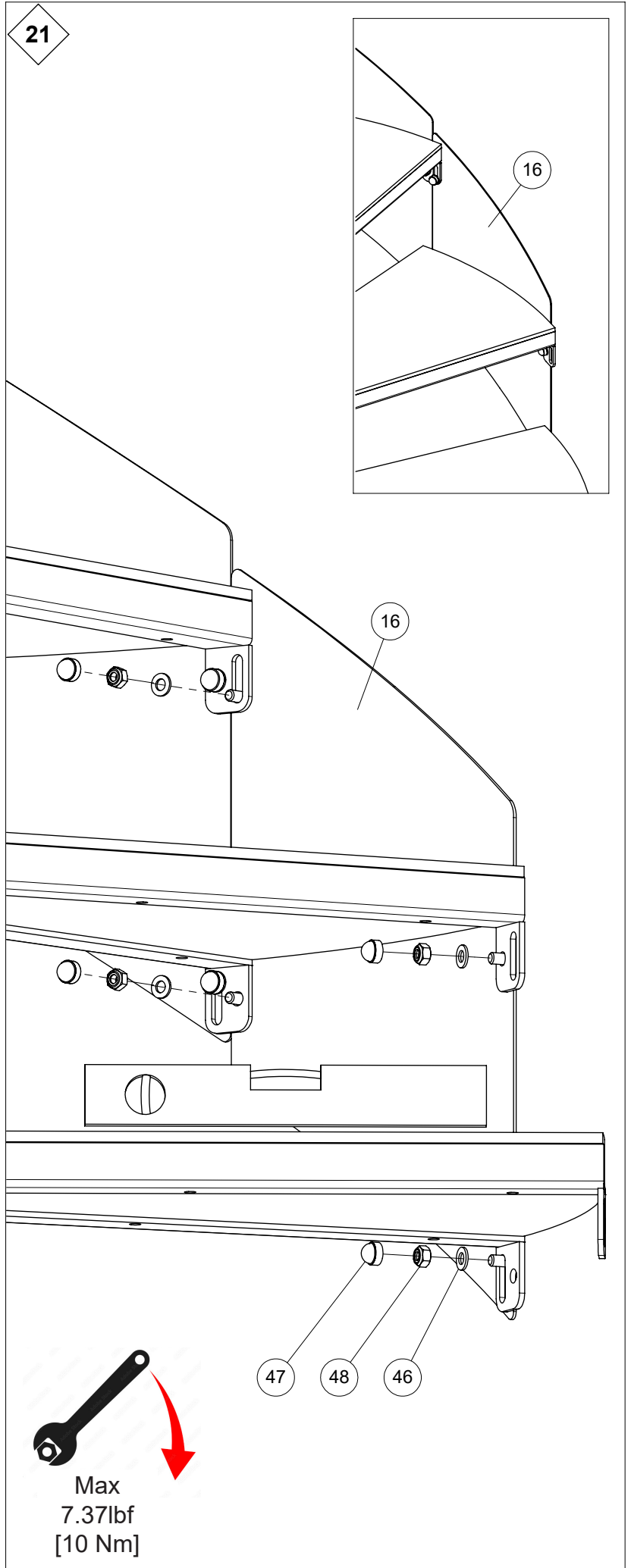



22

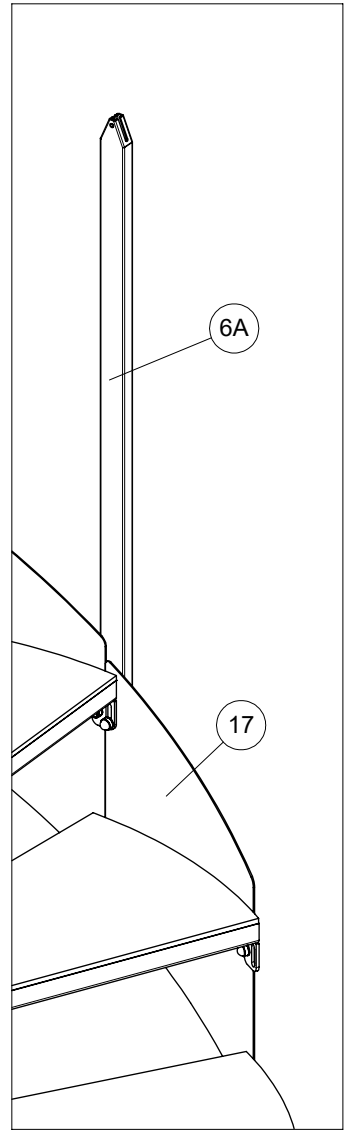
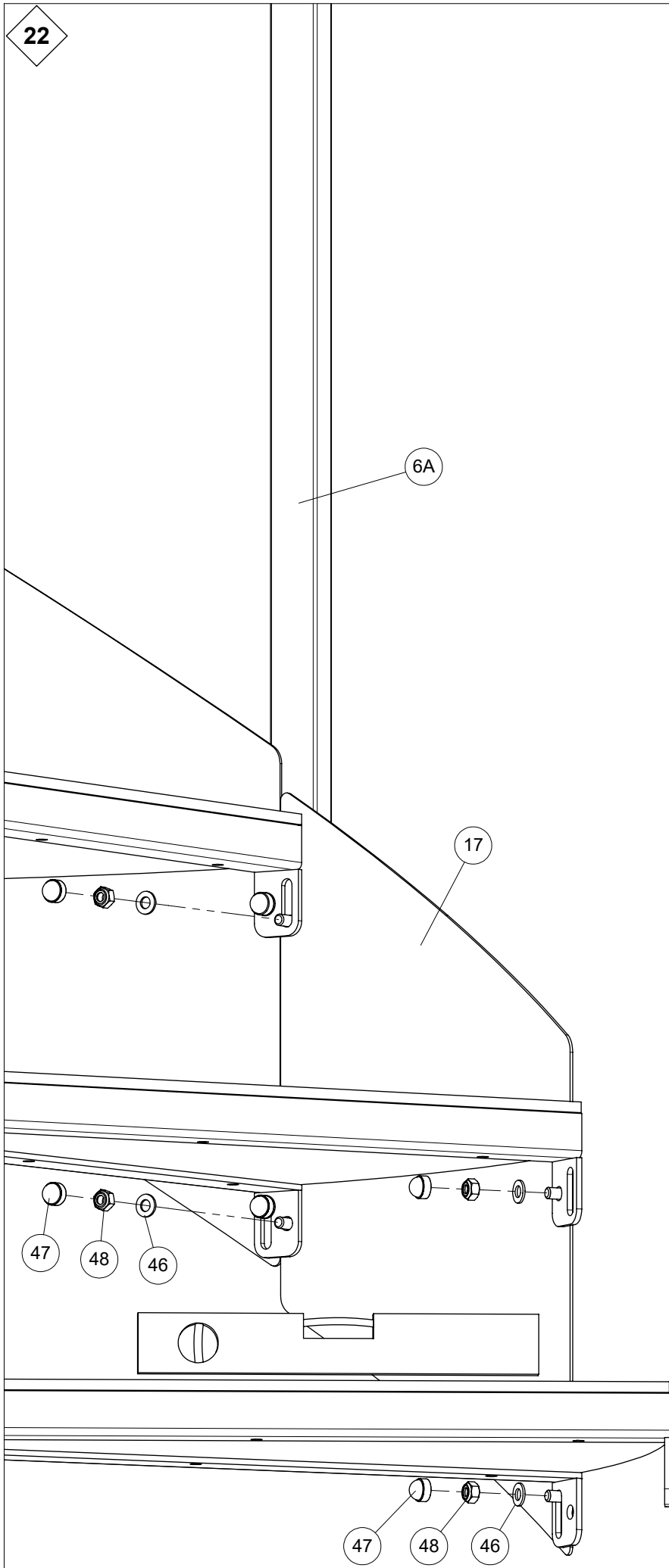

Max  
7.37lbf  
[10 Nm]

23

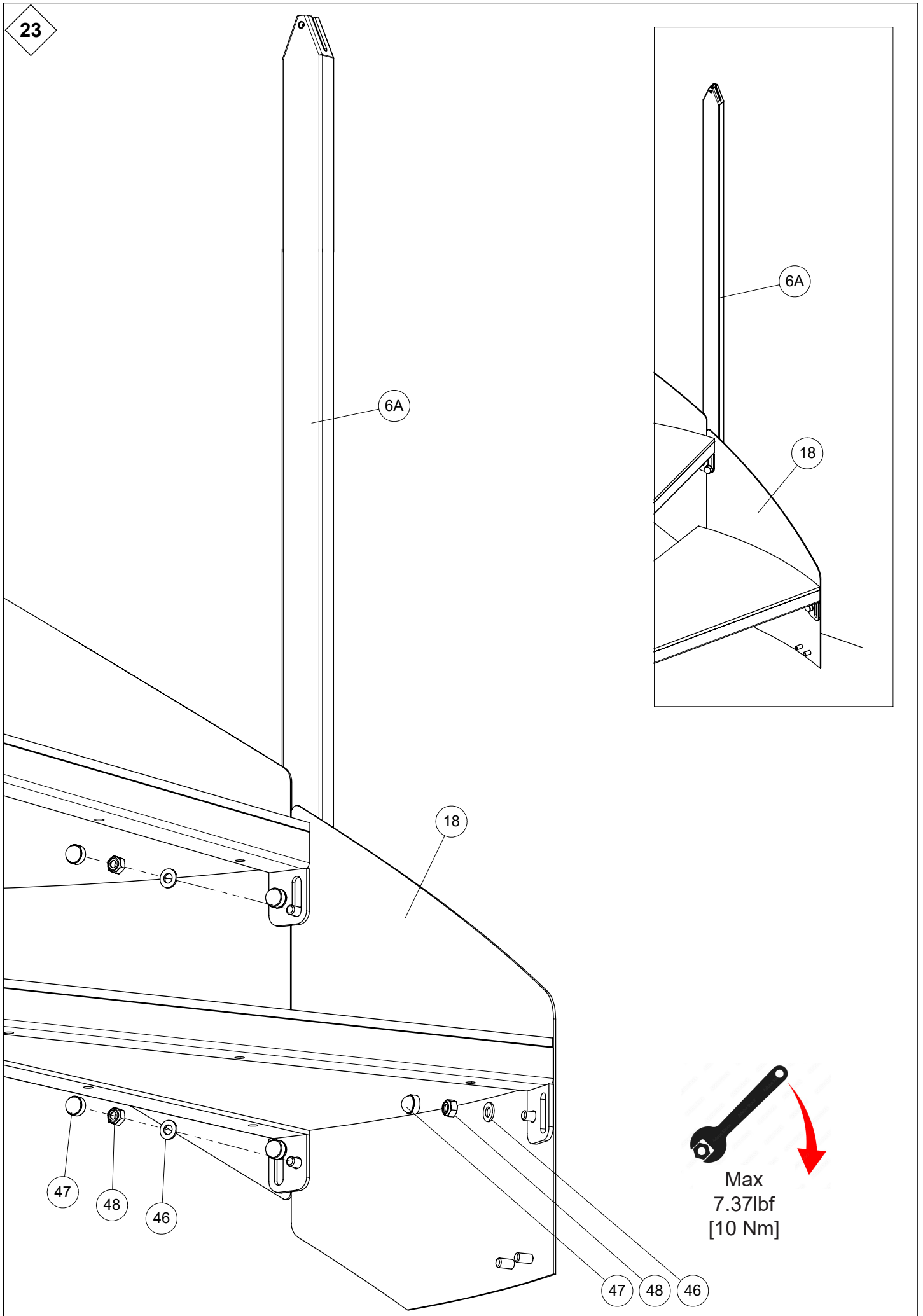

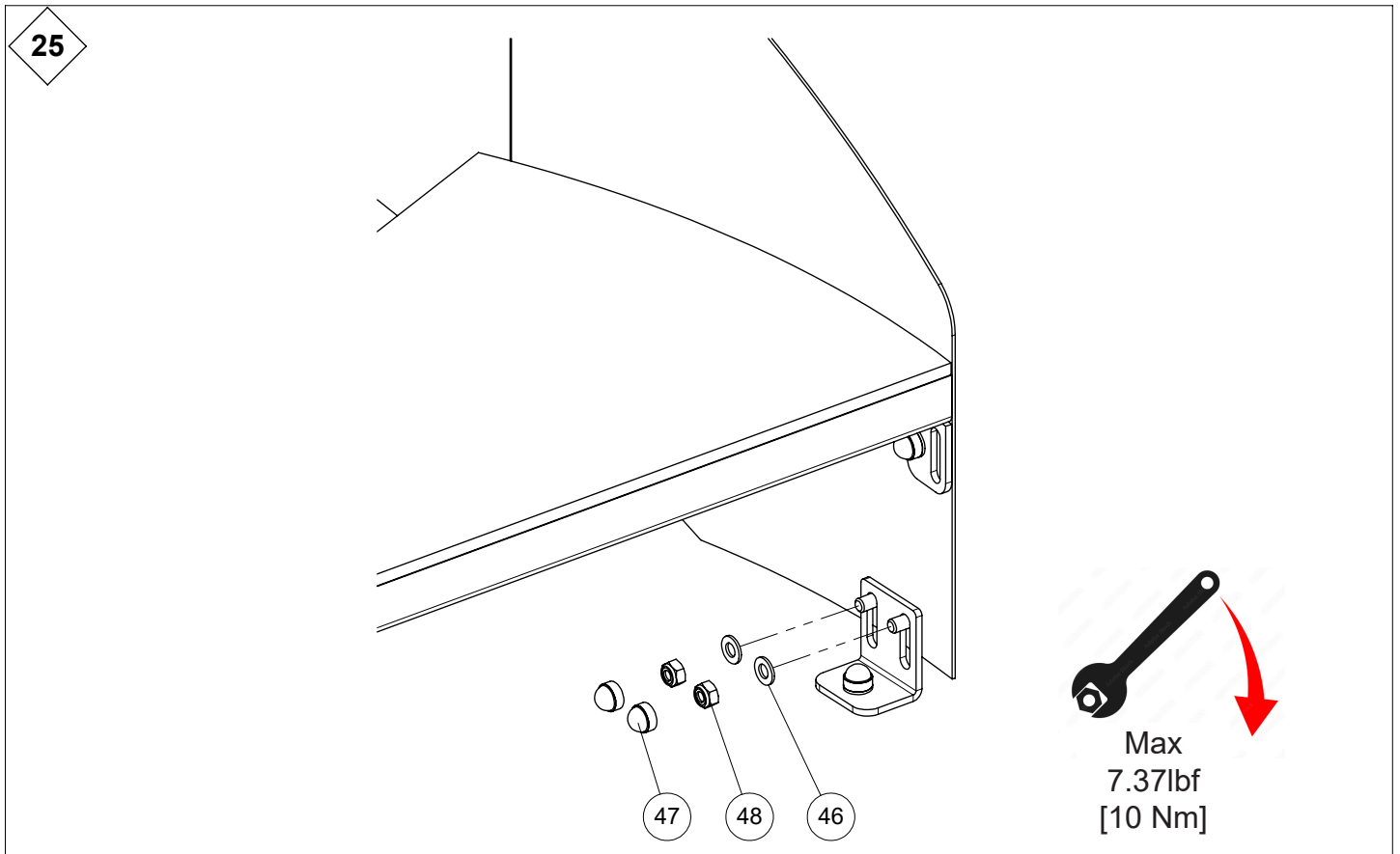
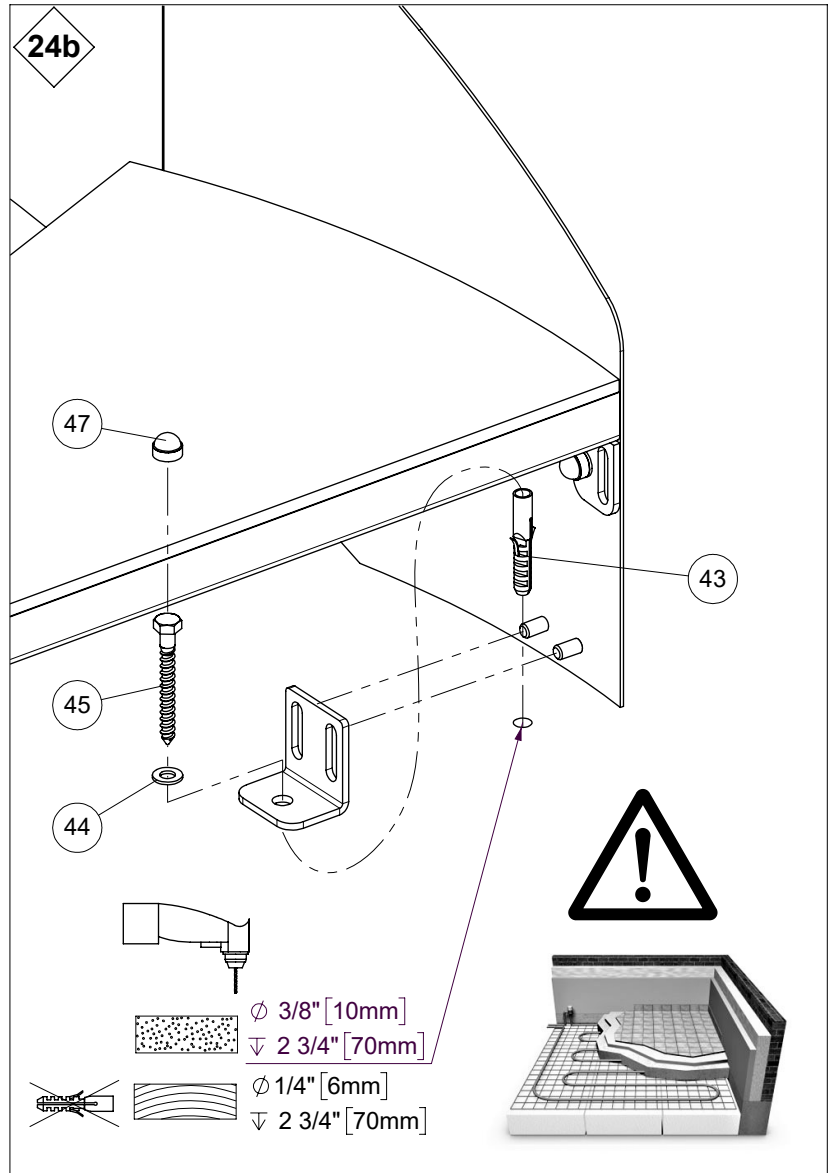
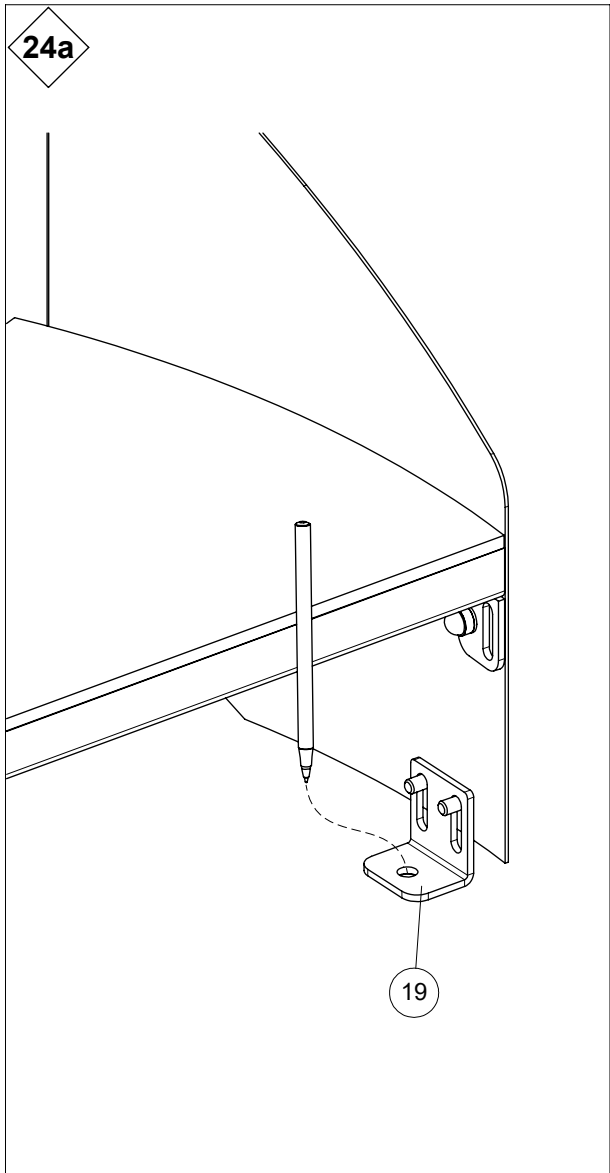

90 °C  
195 °F

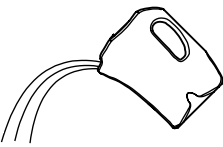

65 - 75 °C  
150 - 165 °F

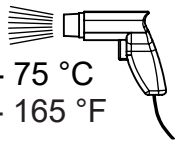

**26a**

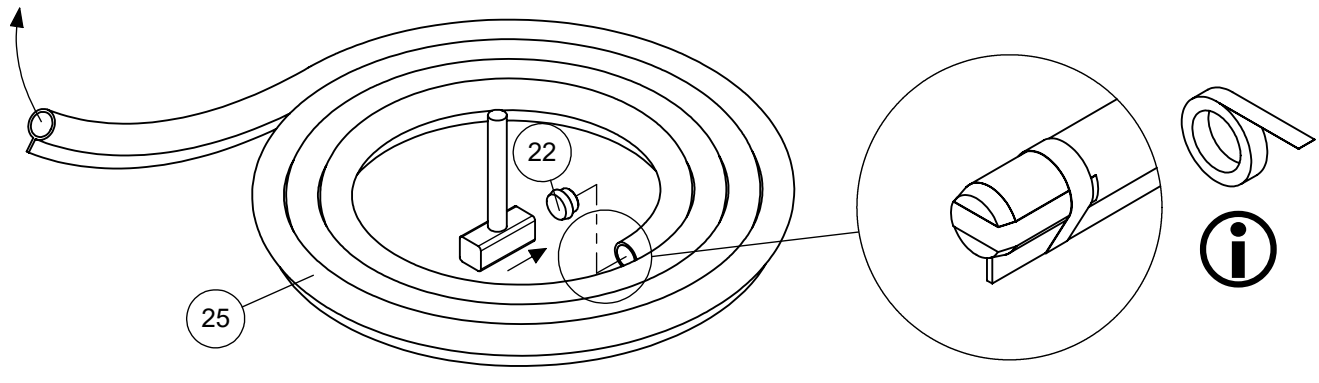

**26b**

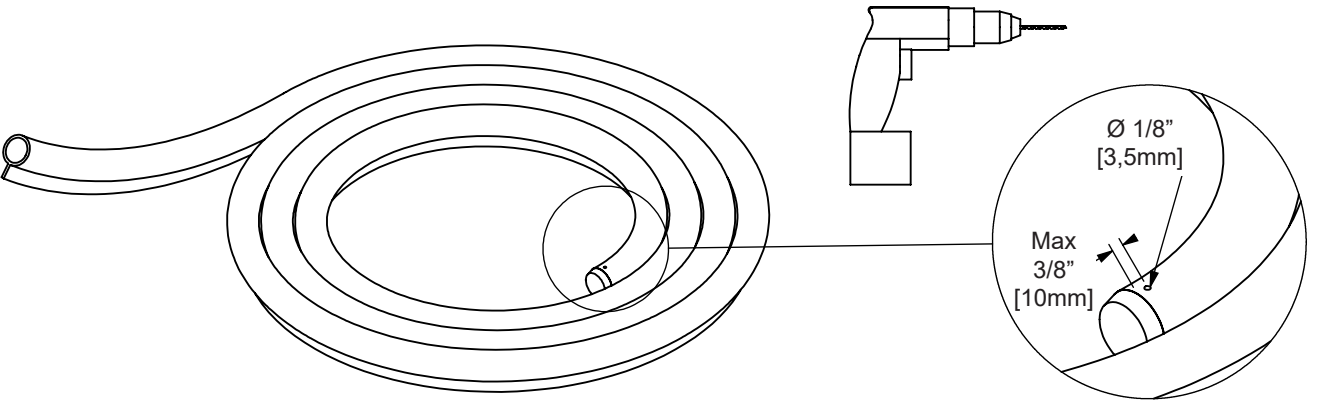

**26c**

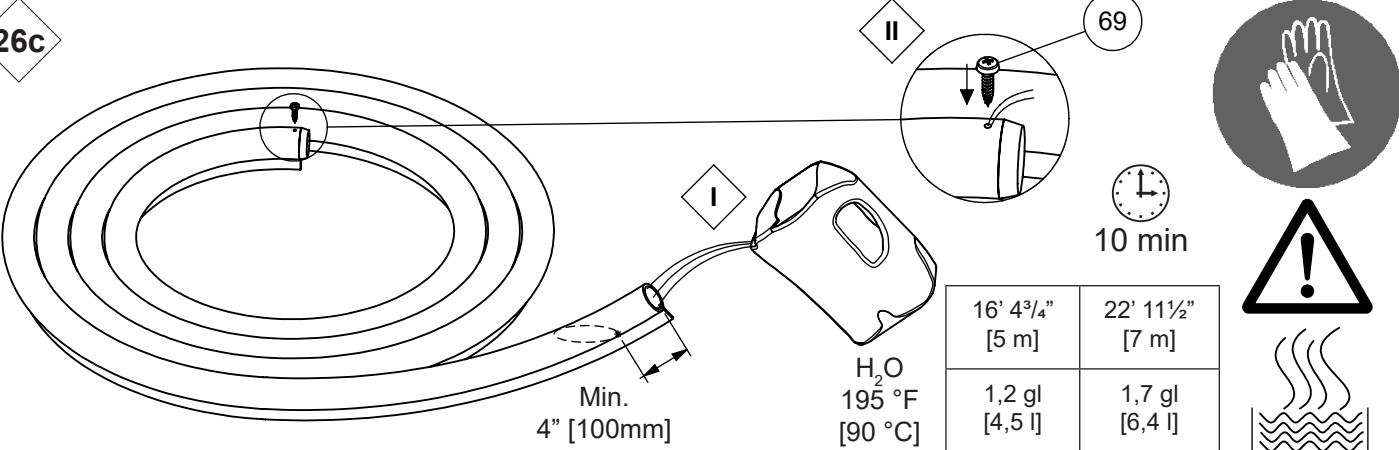

10 min

16' 4 <sup>3</sup> / <sub>4</sub> " [5 m]	22' 11 <sup>1</sup> / <sub>2</sub> " [7 m]
1,2 gl [4,5 l]	1,7 gl [6,4 l]

H<sub>2</sub>O  
195 °F  
[90 °C]

Min.  
4" [100mm]

**26d**

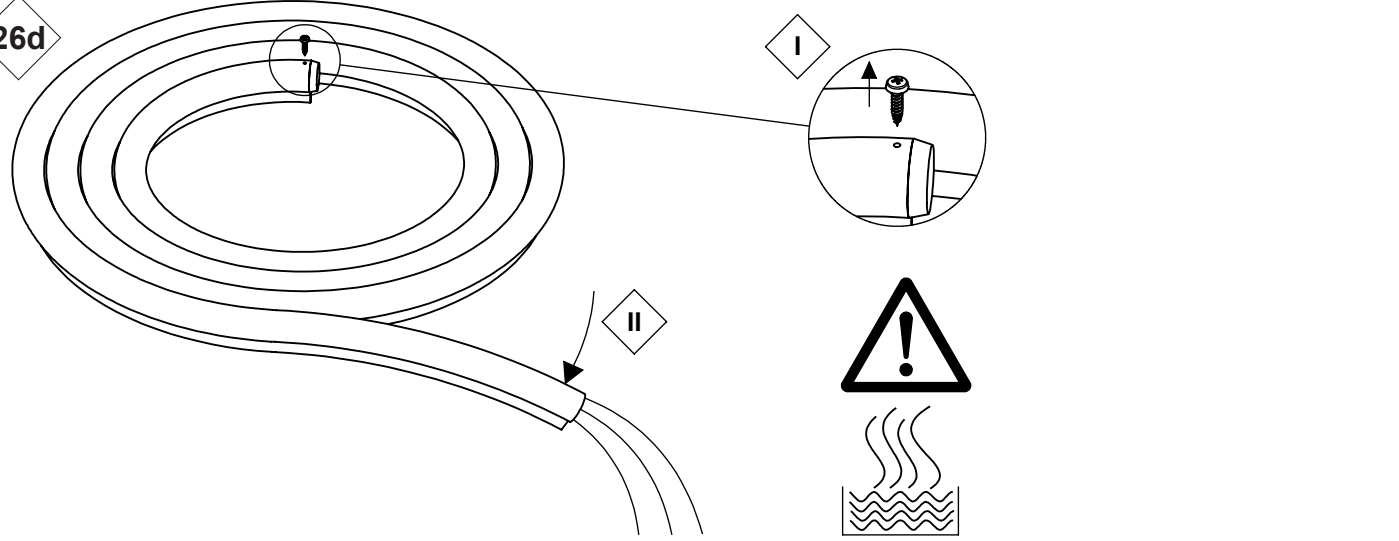

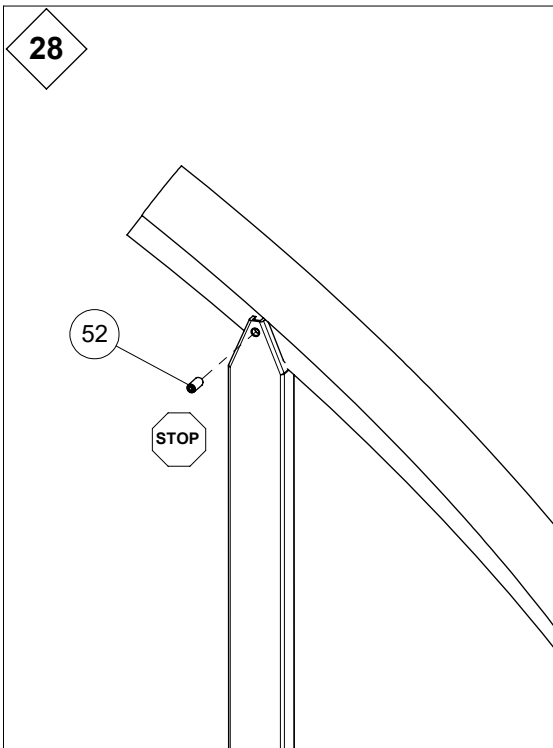
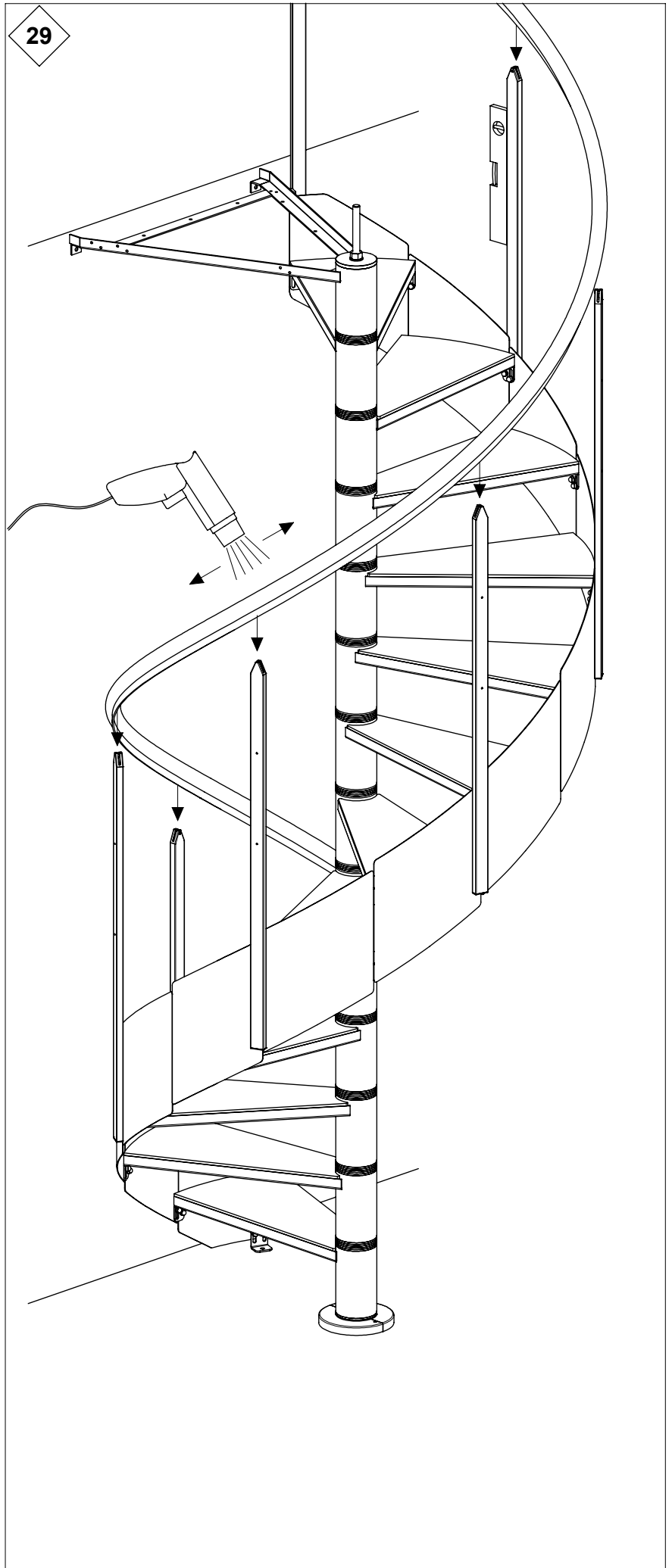
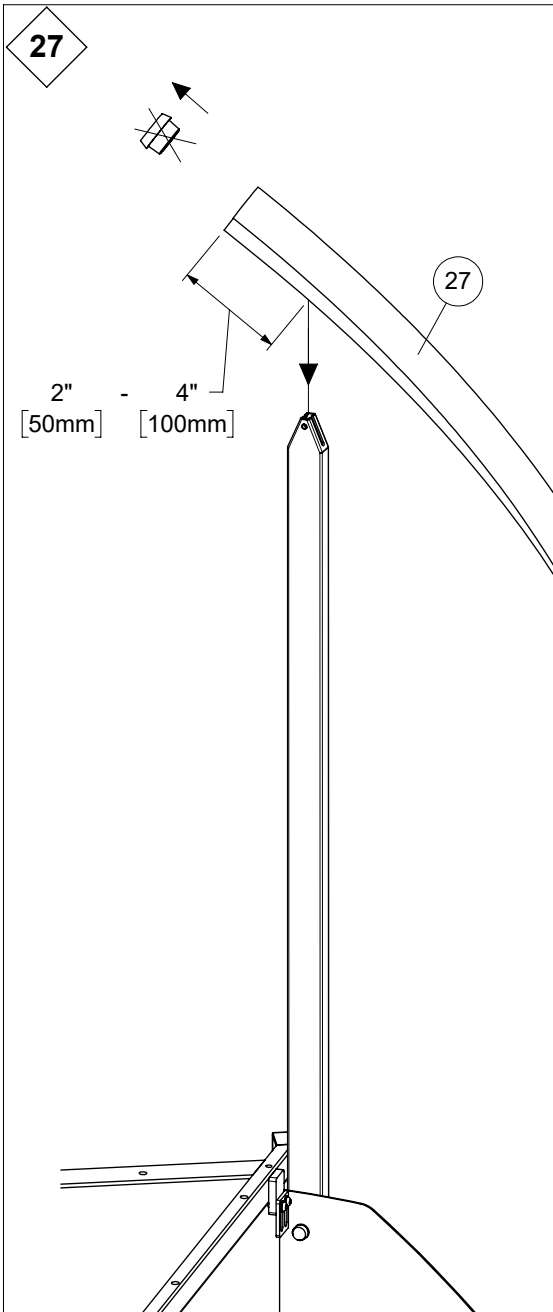

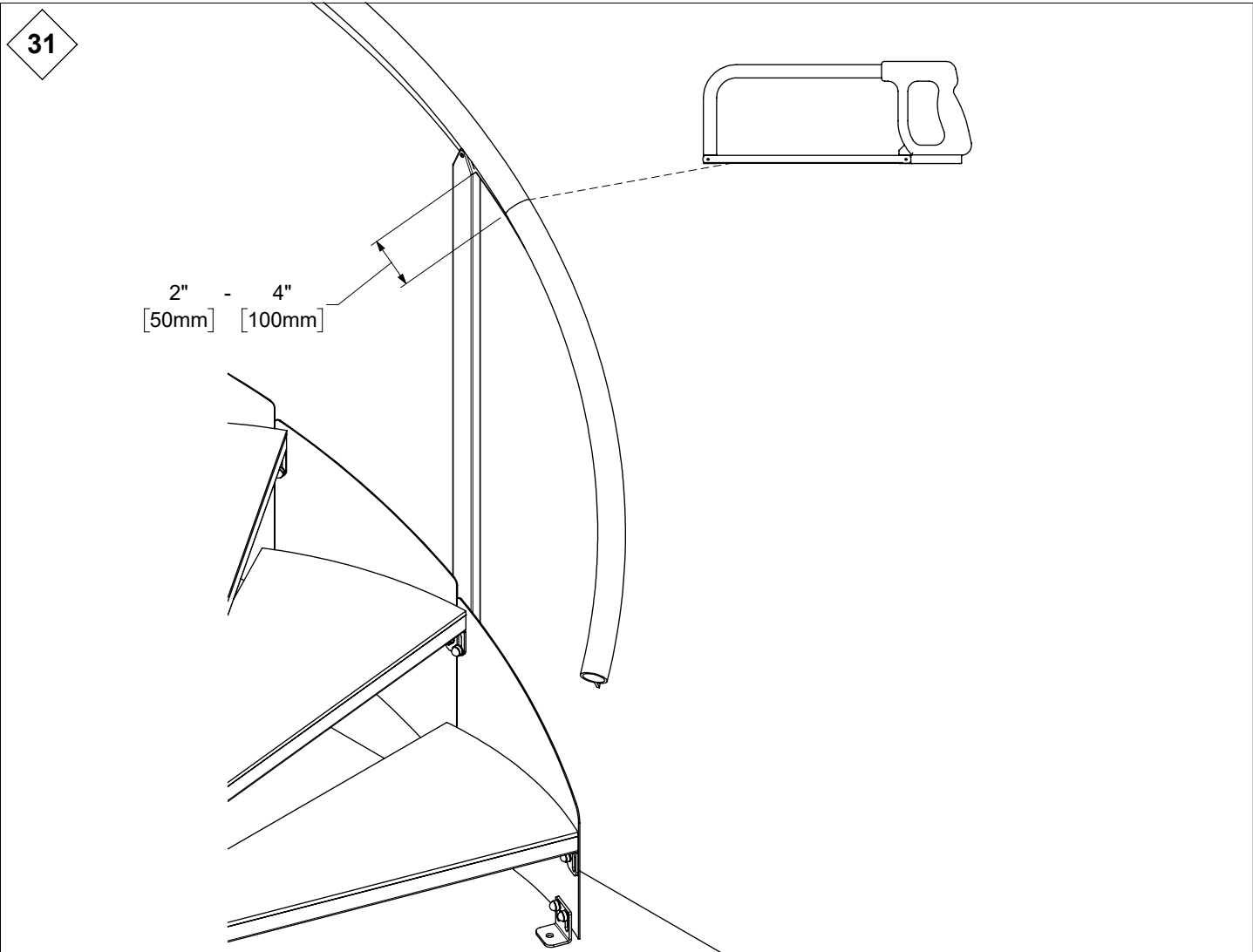
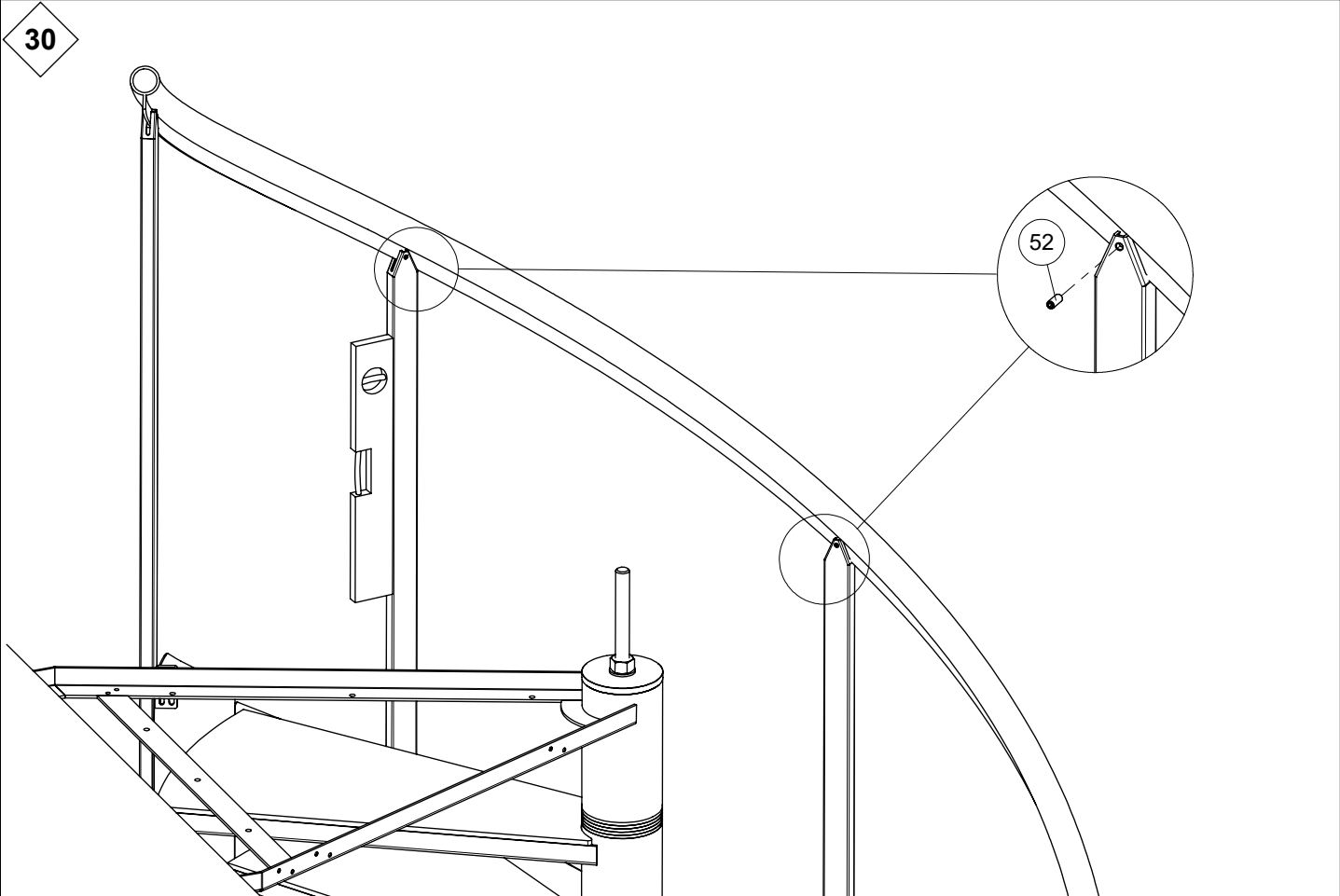

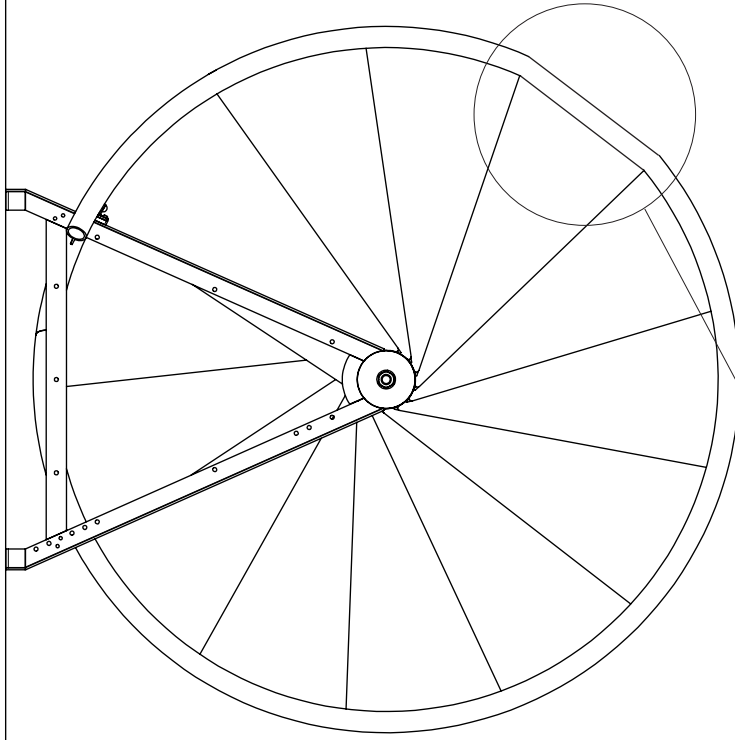

Al calentar el pasamano, por favor preste atención a la distancia entre el pasamano y la pistola de aire caliente. Si la distancia entre la pistola de aire caliente y el pasamano es demasiado corta o/y el pasamano sea demasiado caliente hay un riesgo de que el pasamano se demore y/o se quede quemado.

**Es importante seguir moviendo la pistola de aire caliente para asegurar que cierto puntos del pasamano no sea demasiado caliente.**

Guantes de protección deben ser utilizados durante todo el tiempo trabajando con el pasamano caliente.

When heating the handrail, please pay attention to the distance between the handrail and the hot air gun. If the contact between the hot air gun and the handrail is too close or too hot there is a risk that the handrail will be deformed and/or burned.

**It is important to keep moving the hot air gun in order to ensure that particular points on the handrail do not become too hot.**

Protective gloves should be worn while working with the hot handrail.

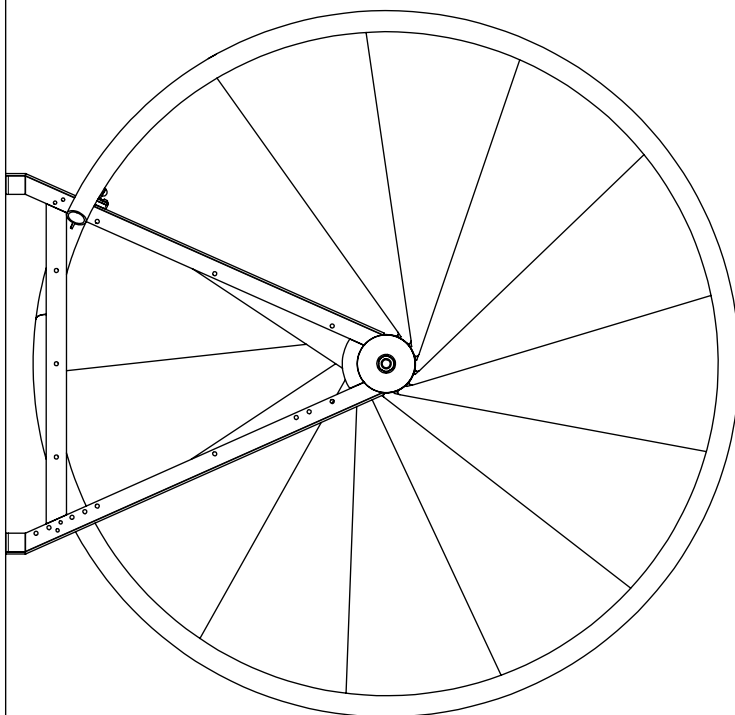
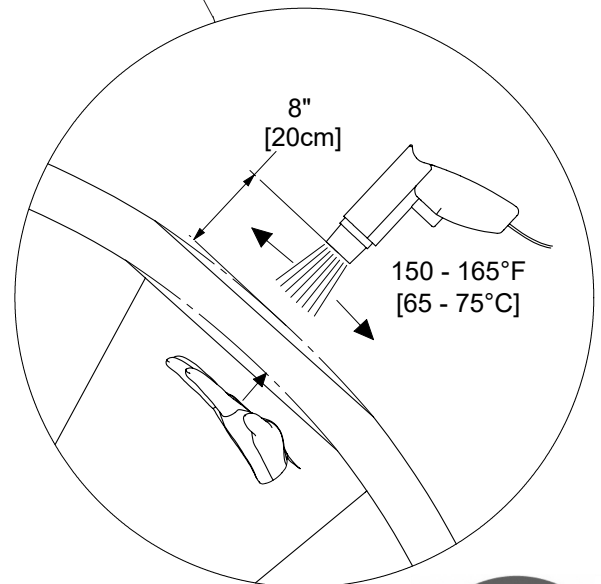

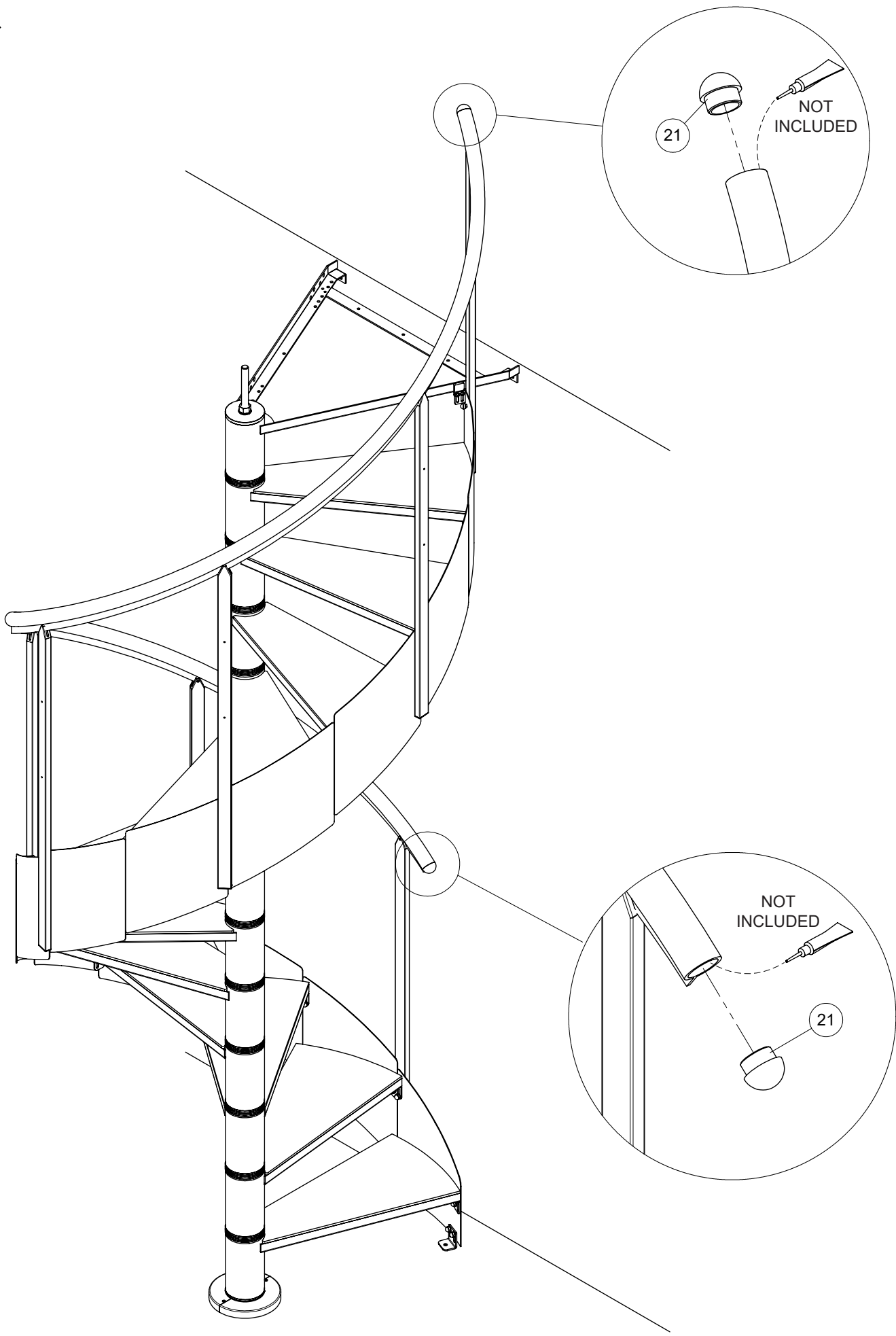



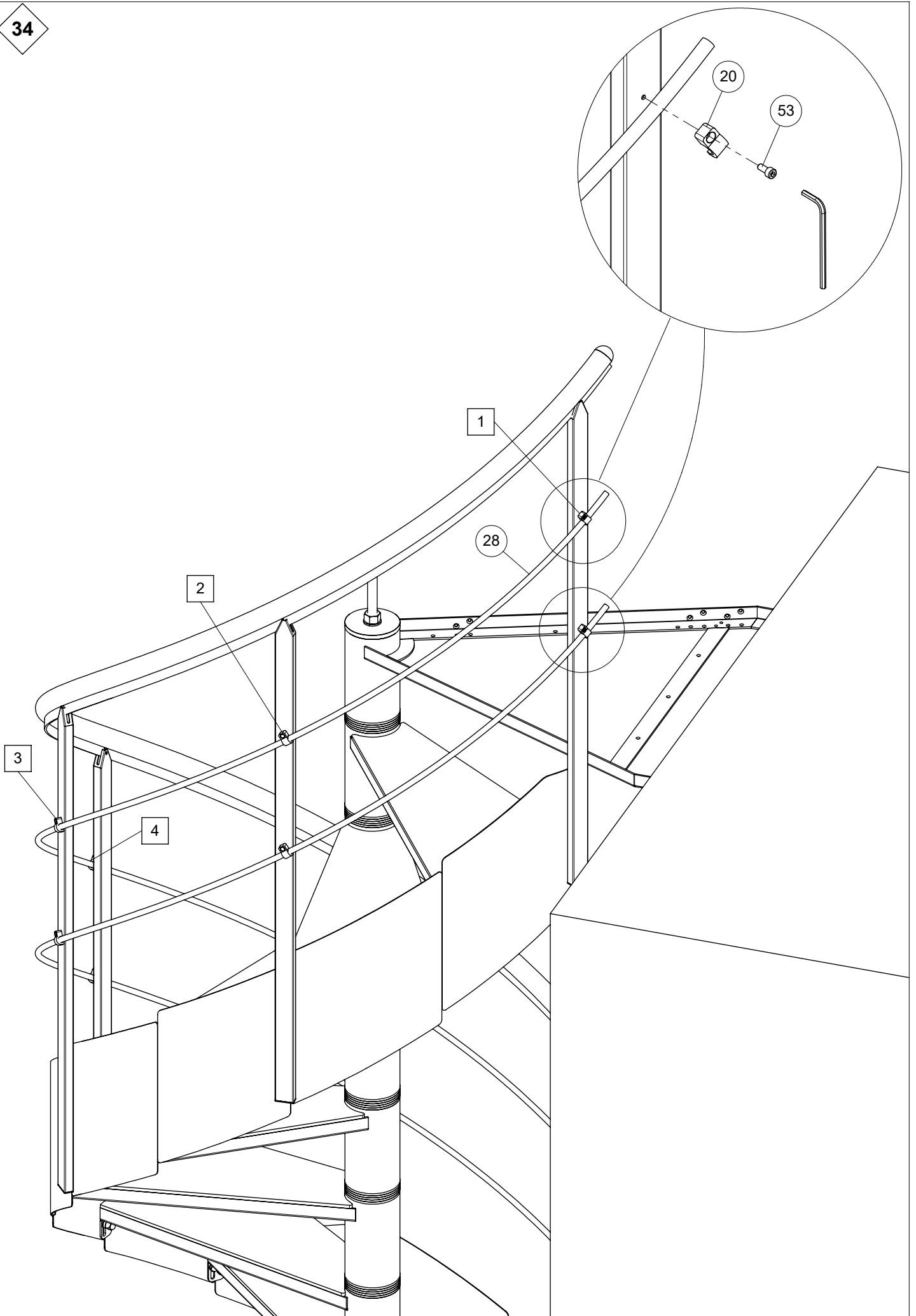

35

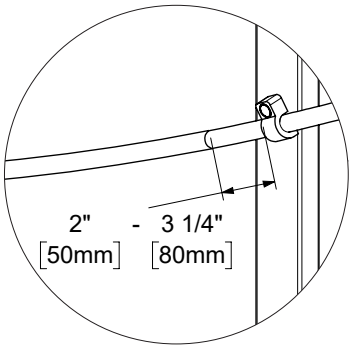
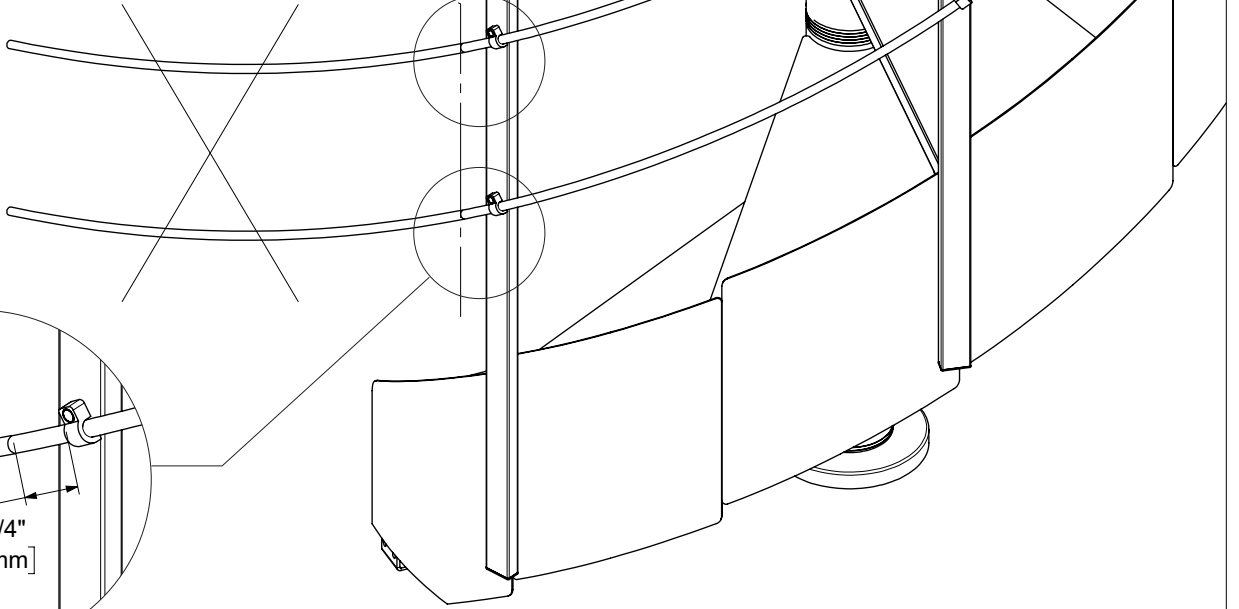
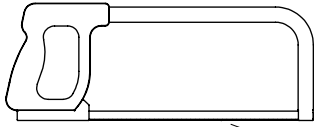

36

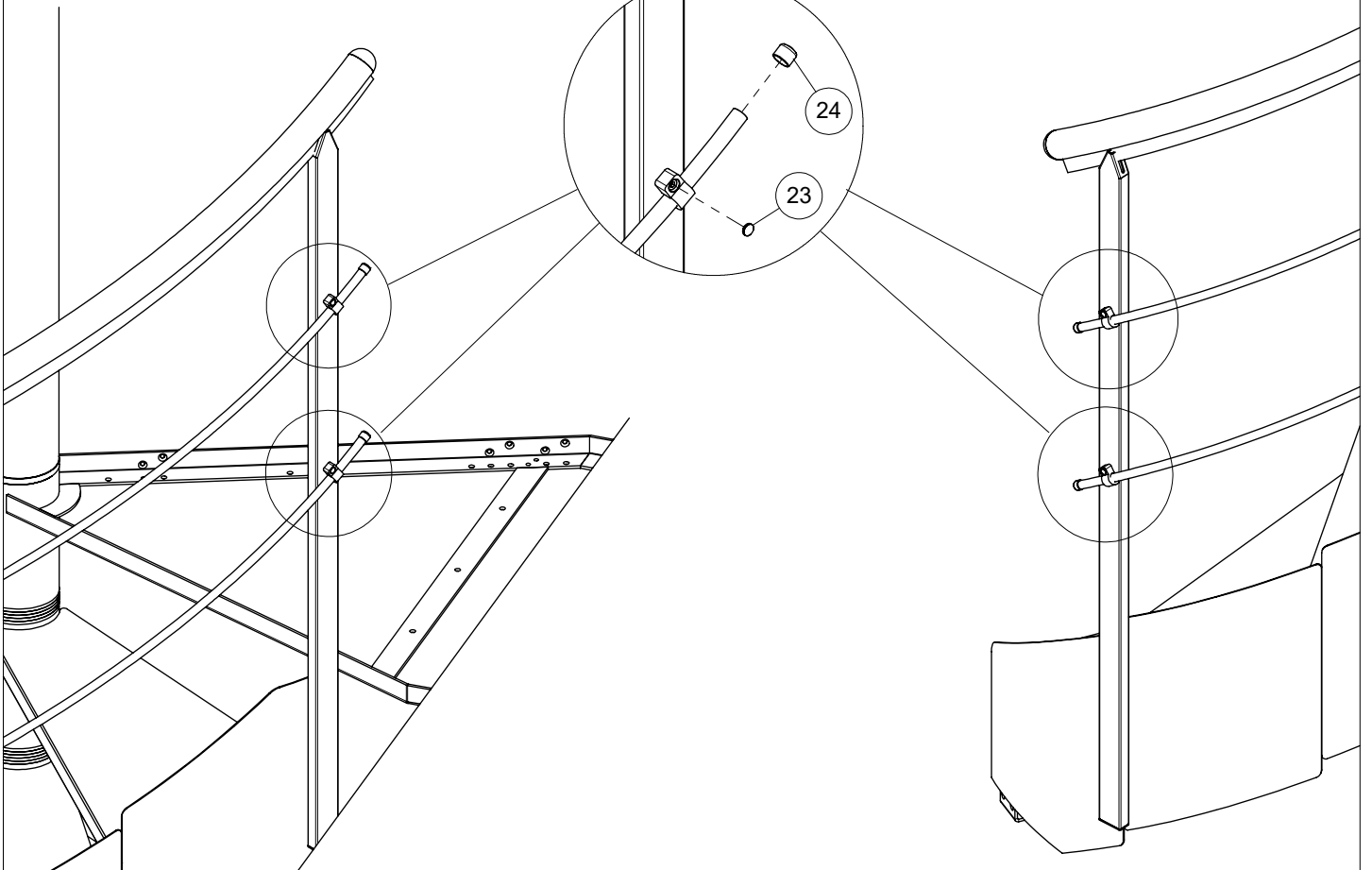
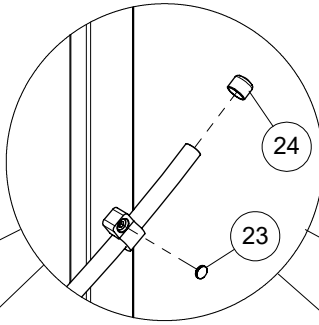

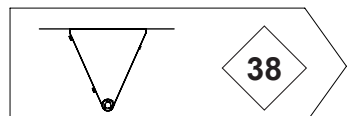
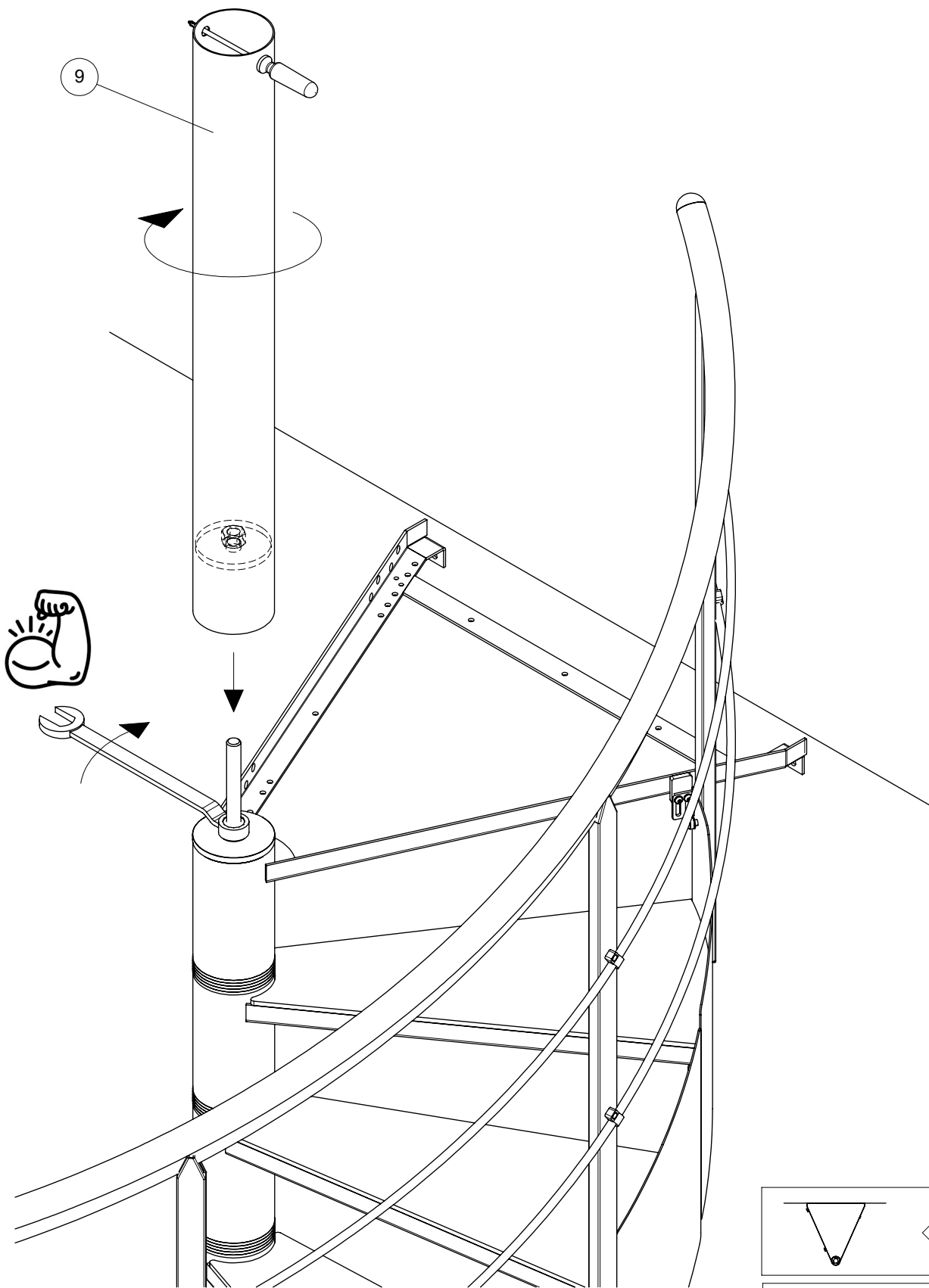

38

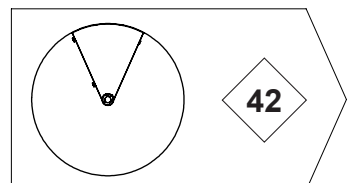

42

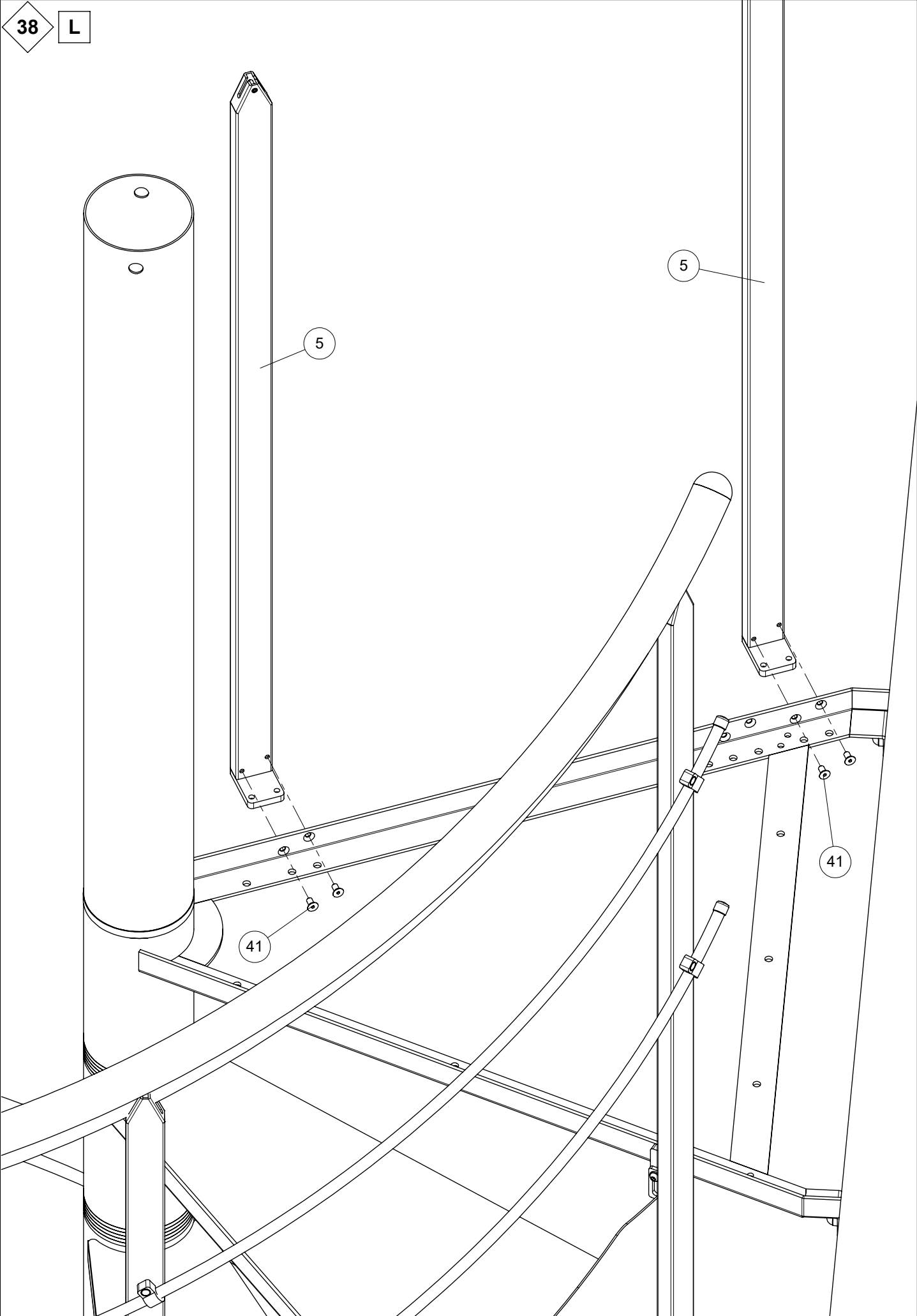

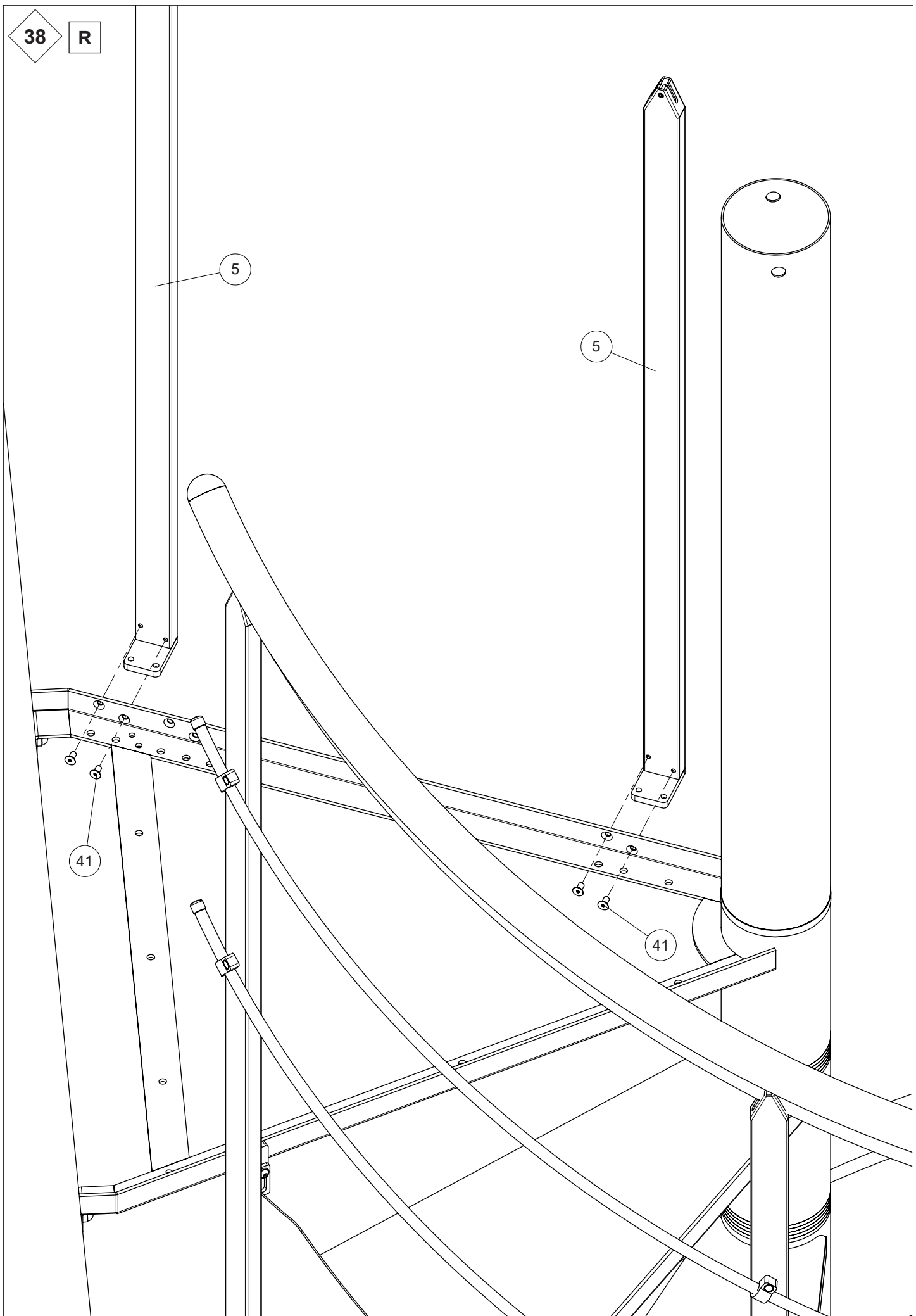

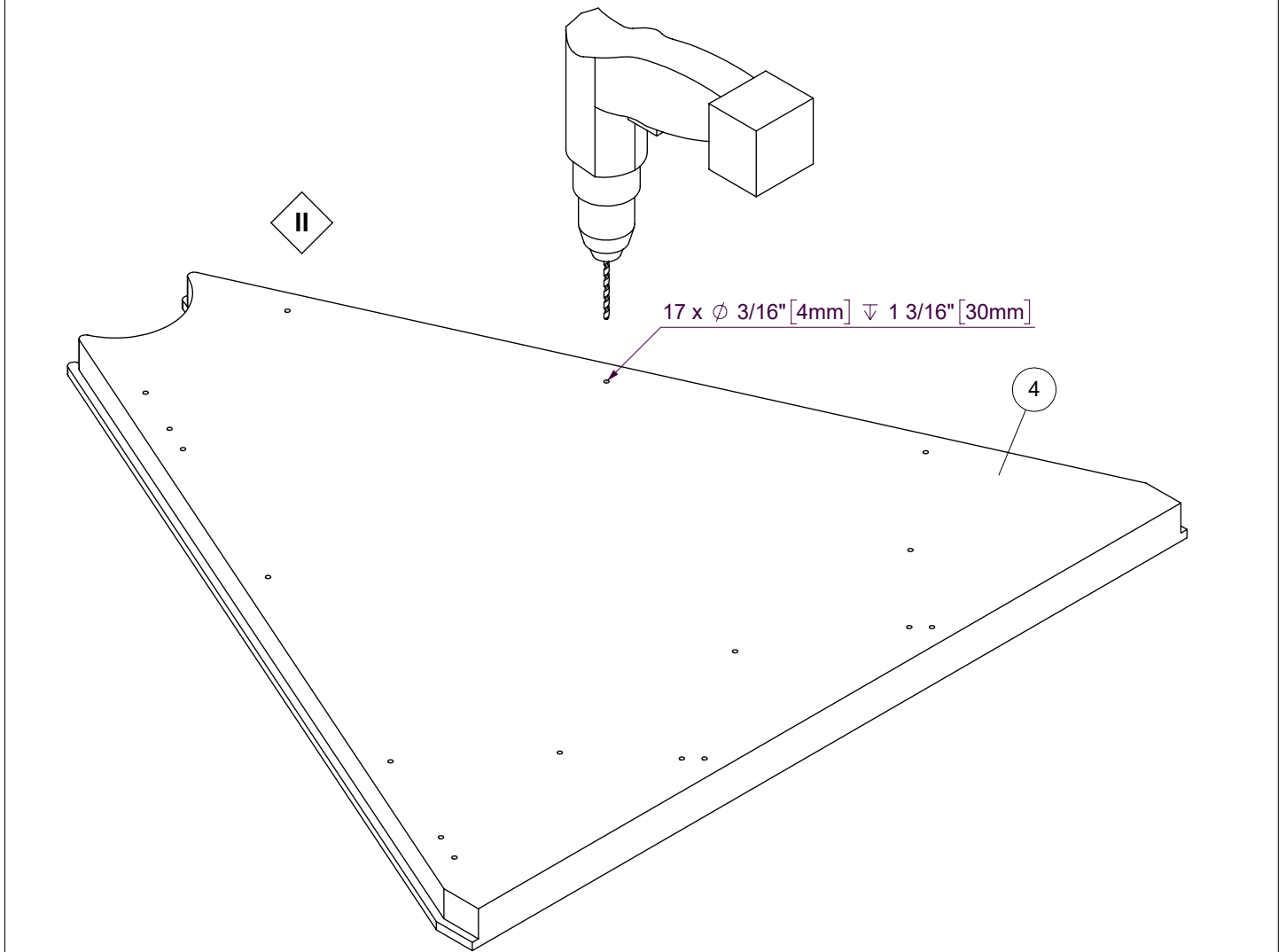
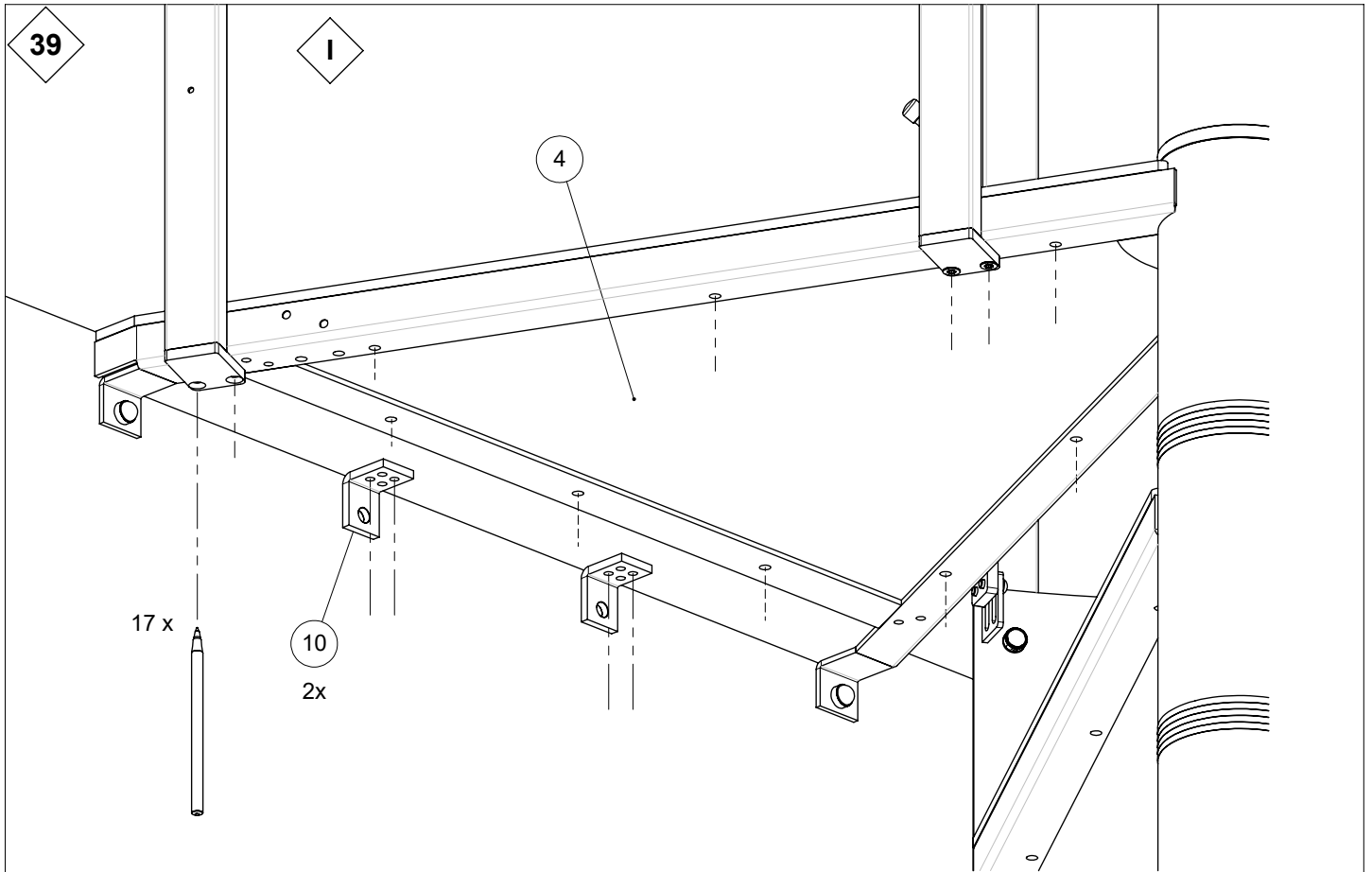

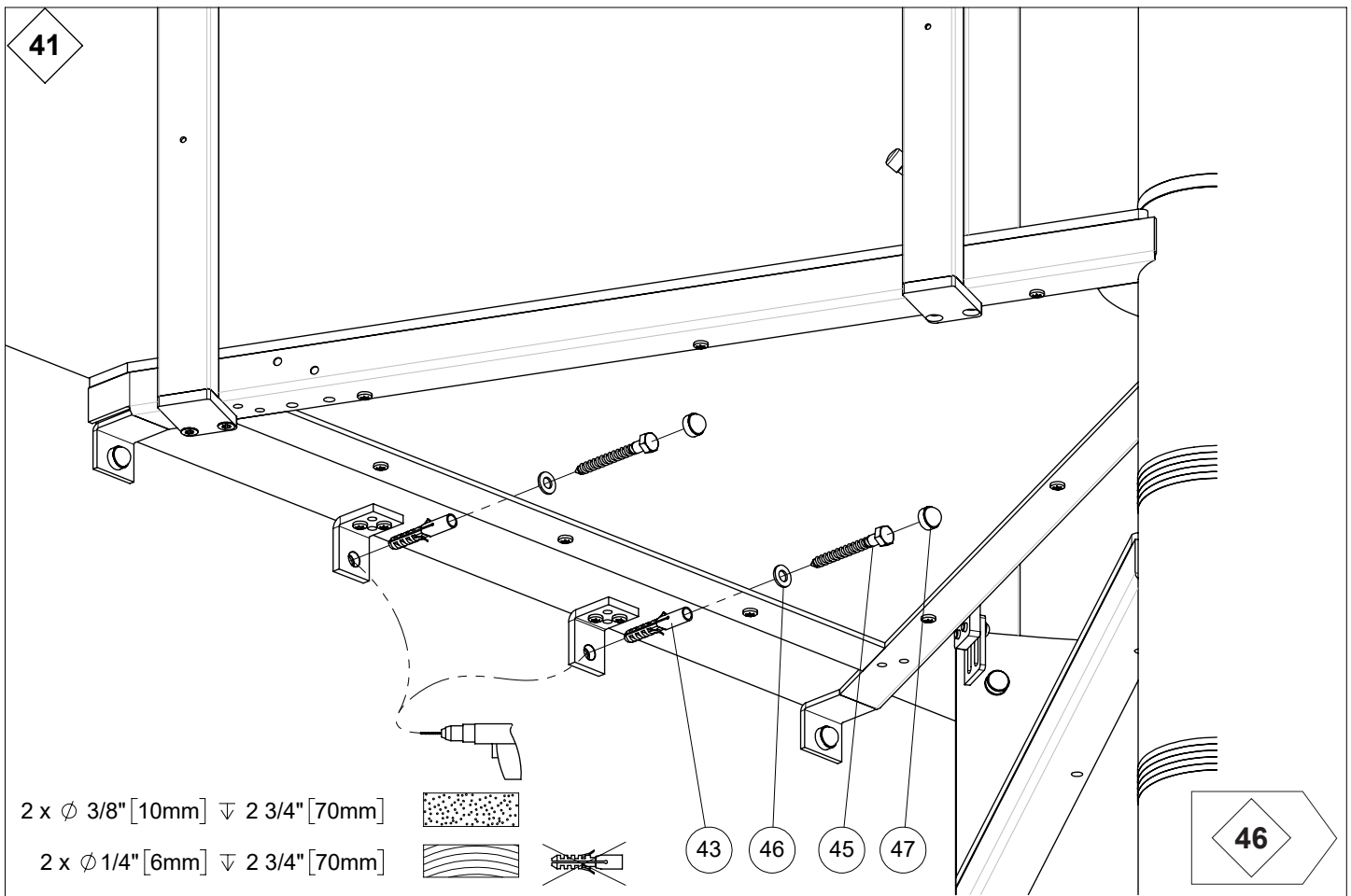
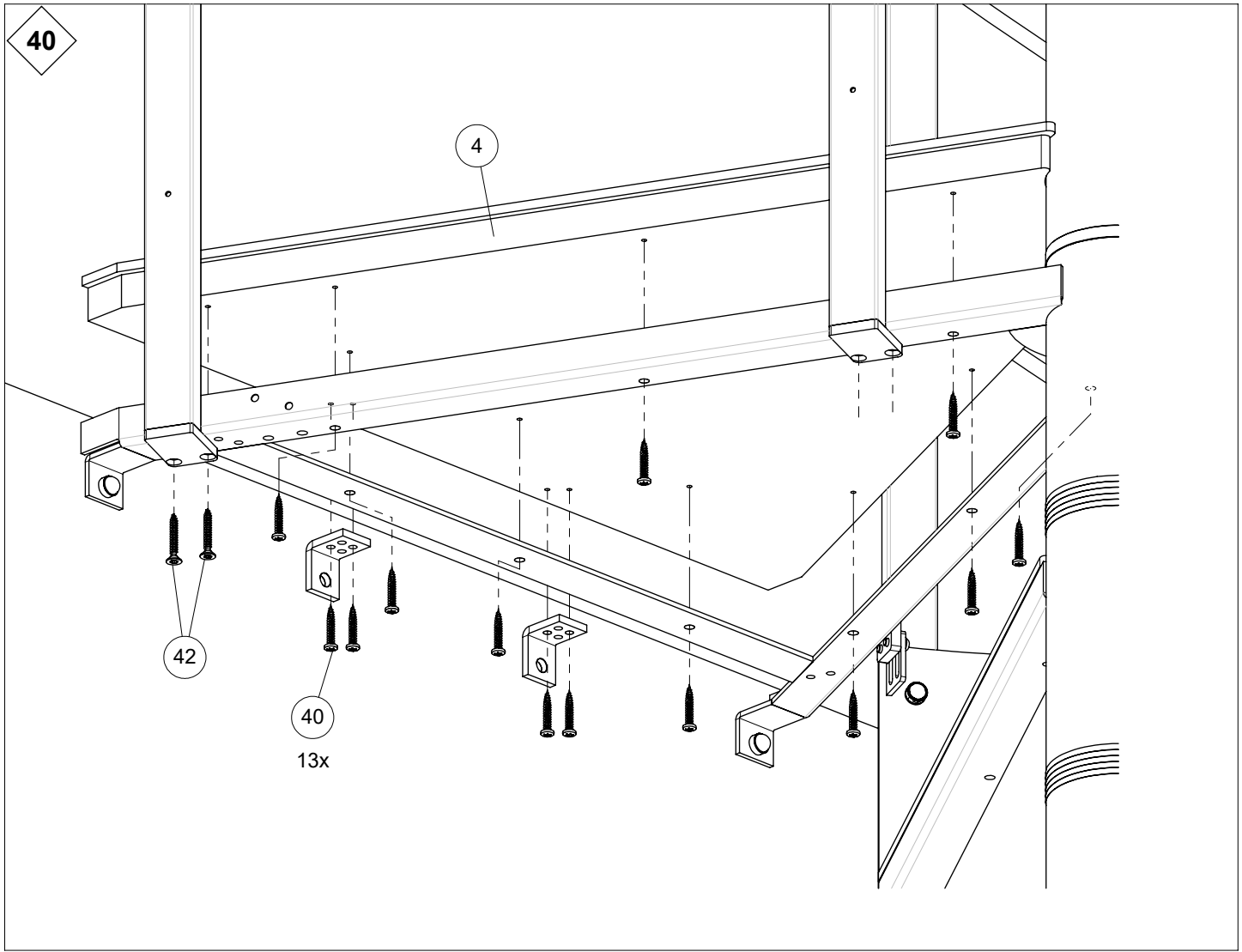

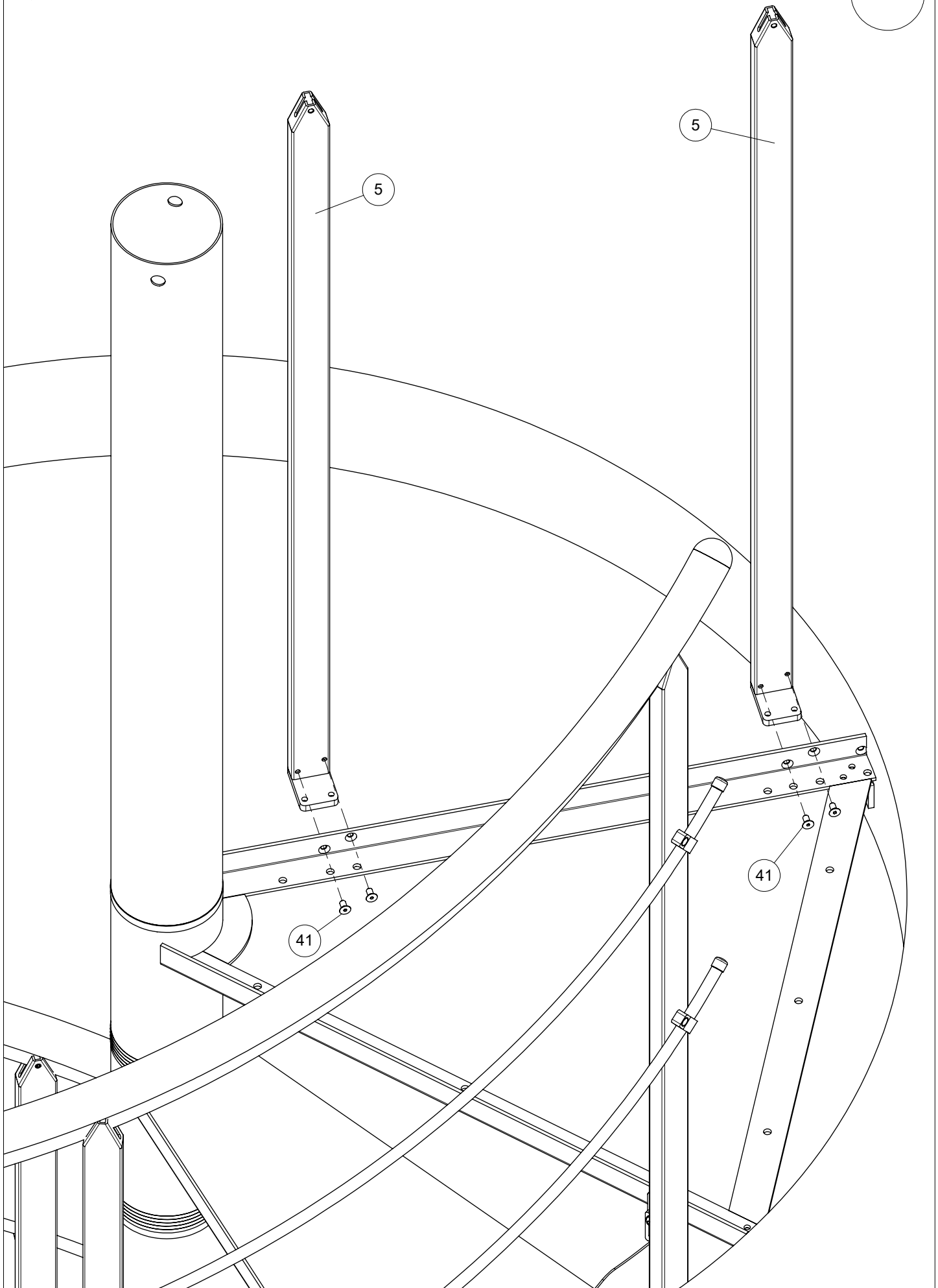
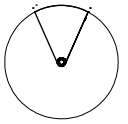



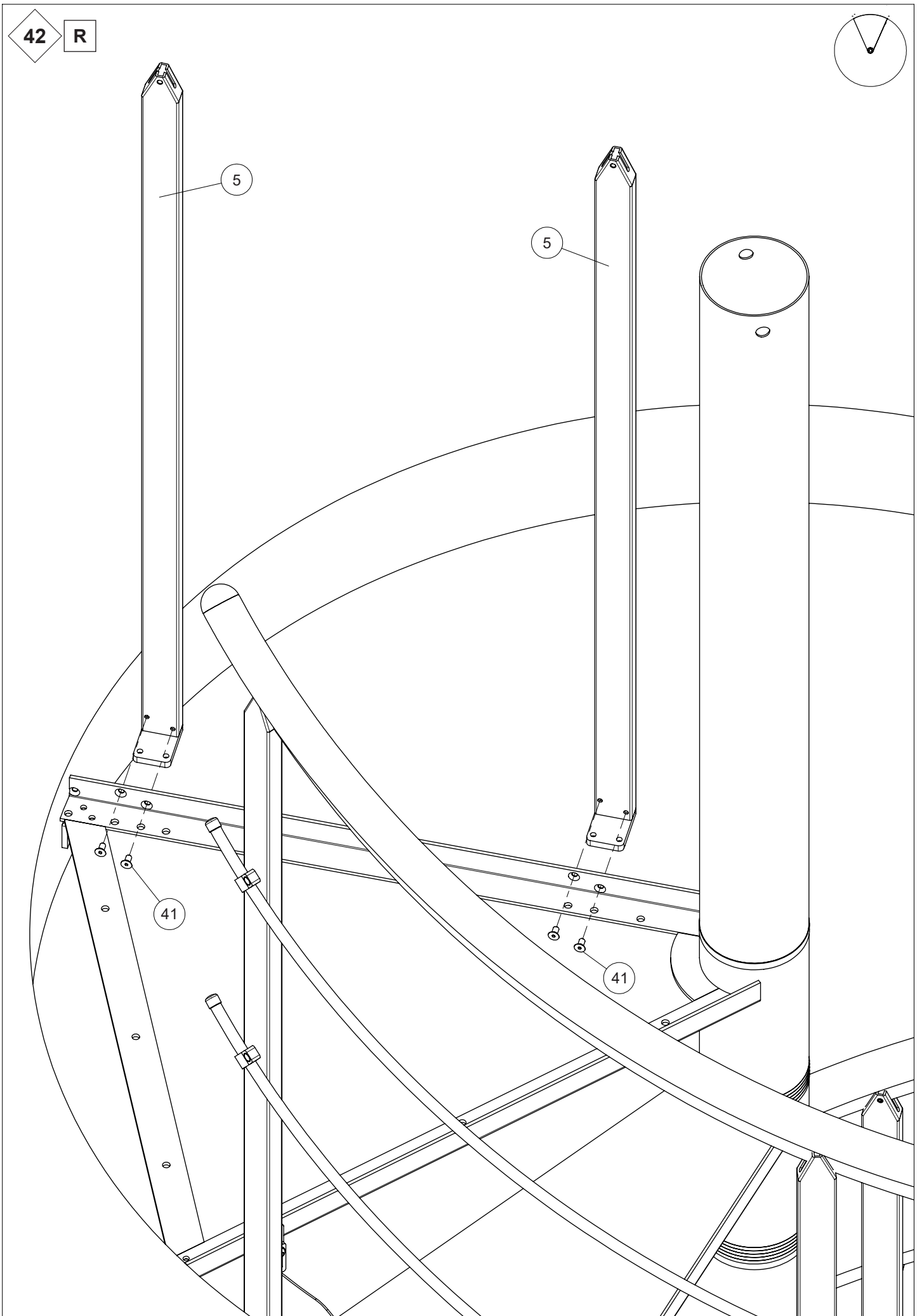
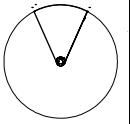

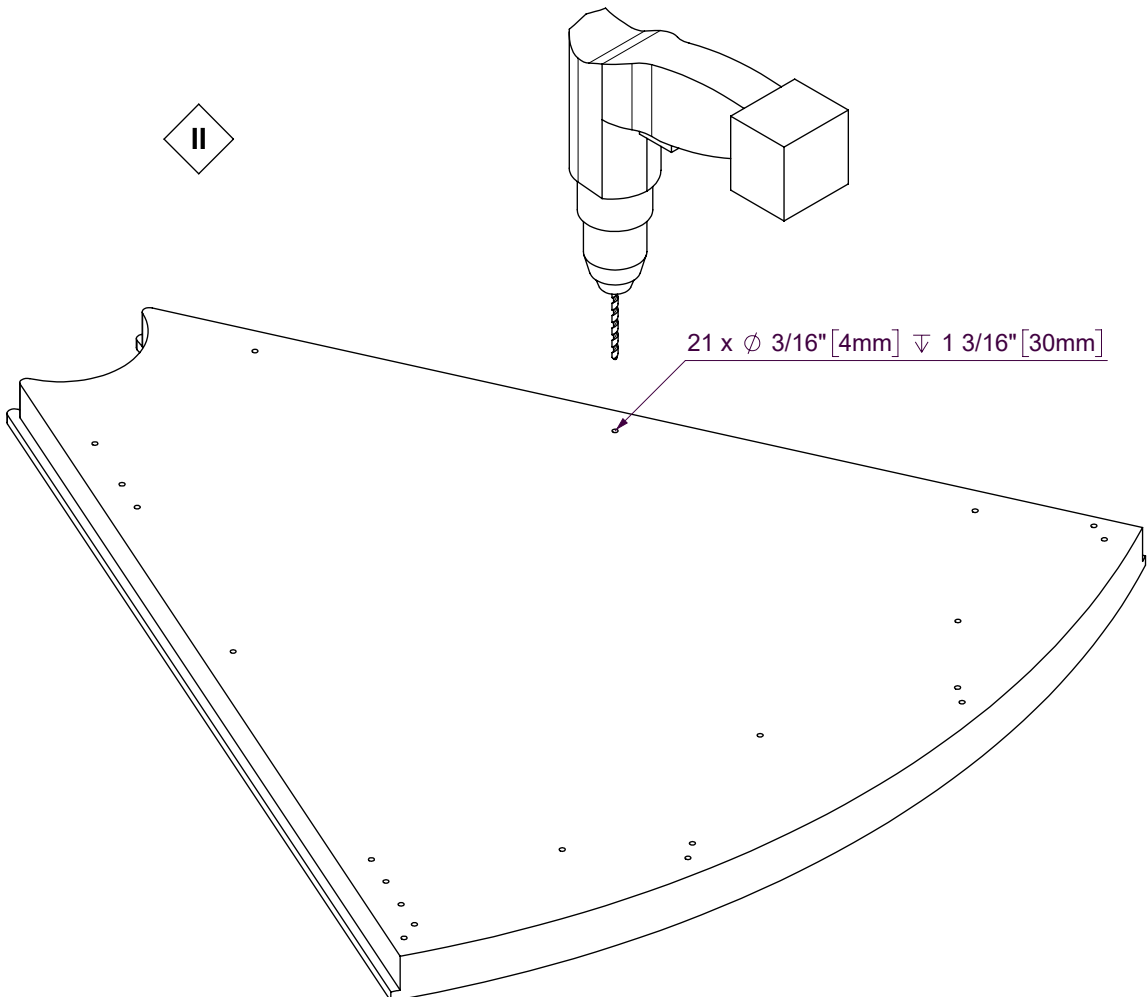
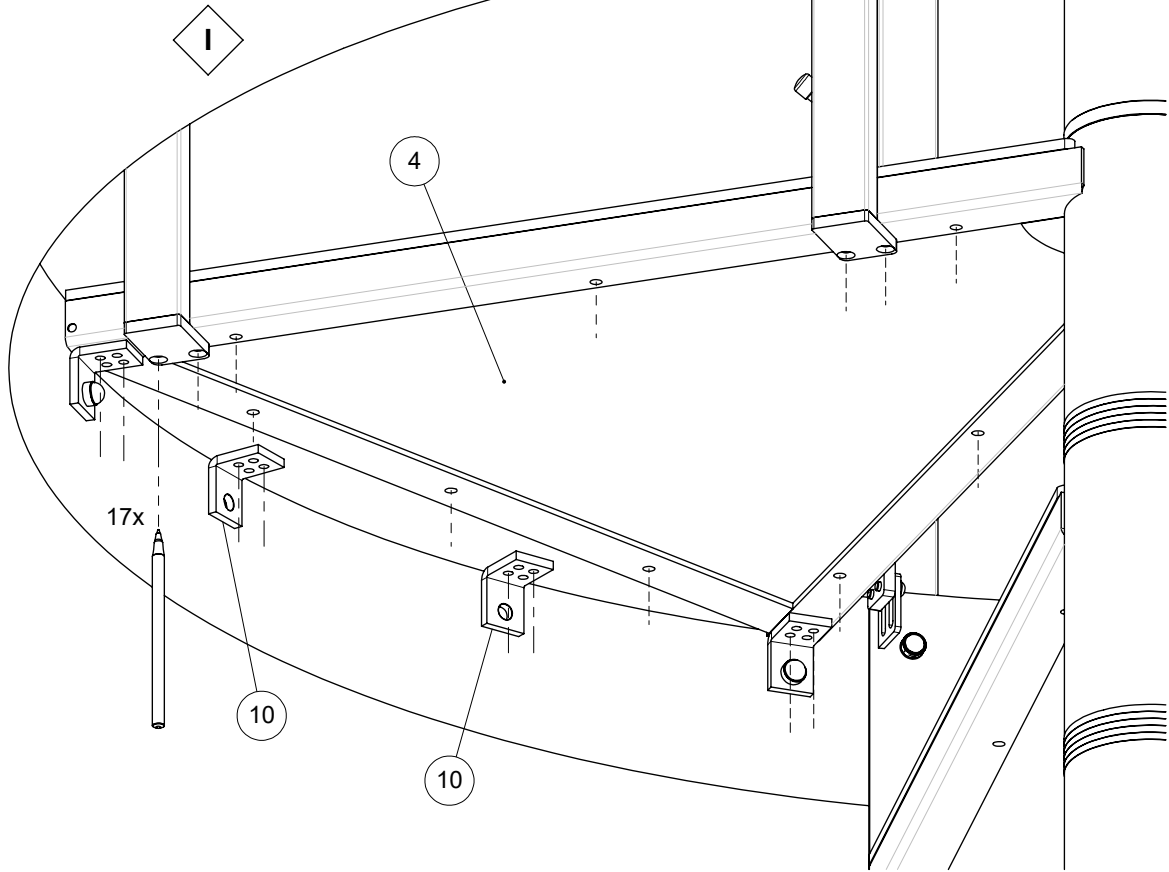
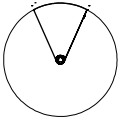

44

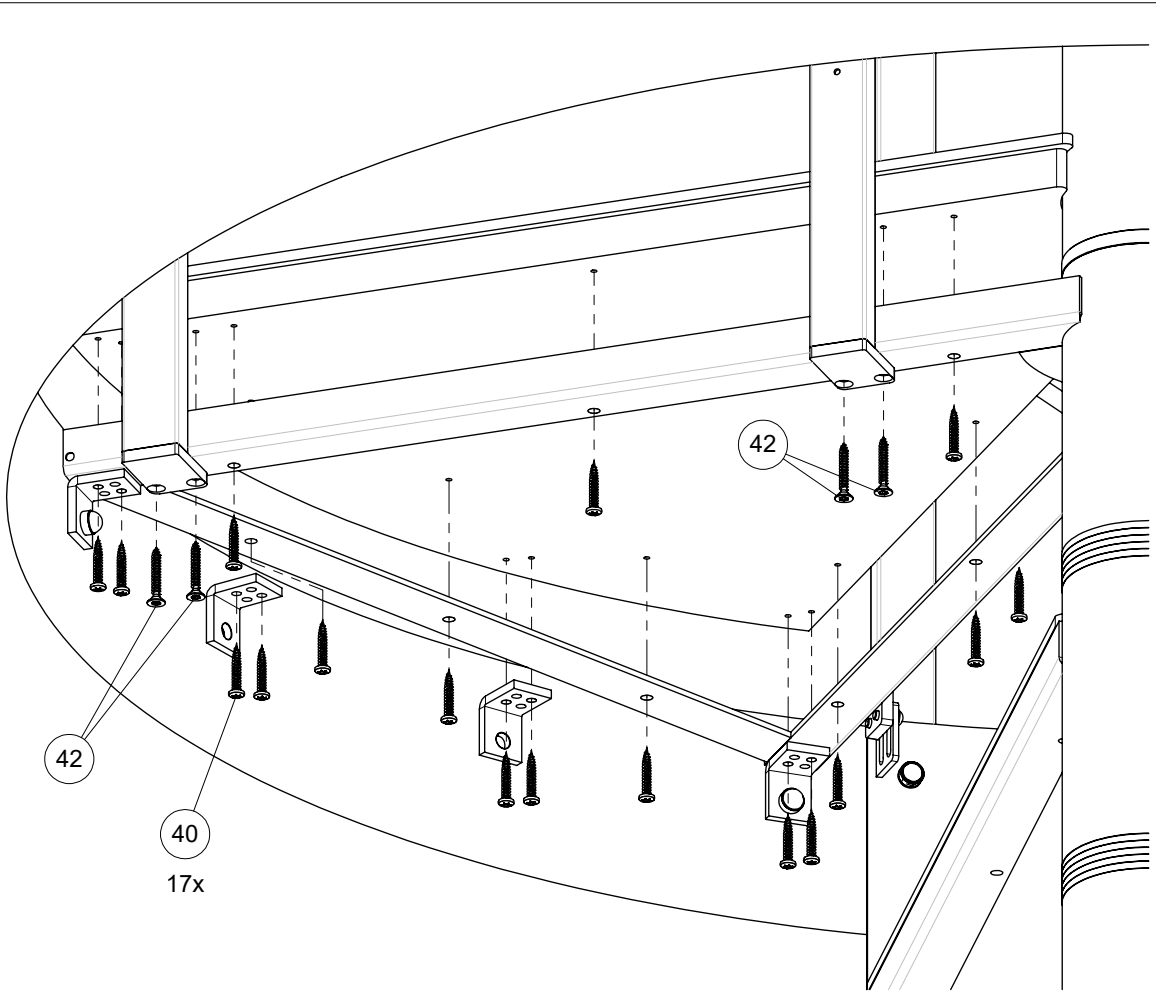

45

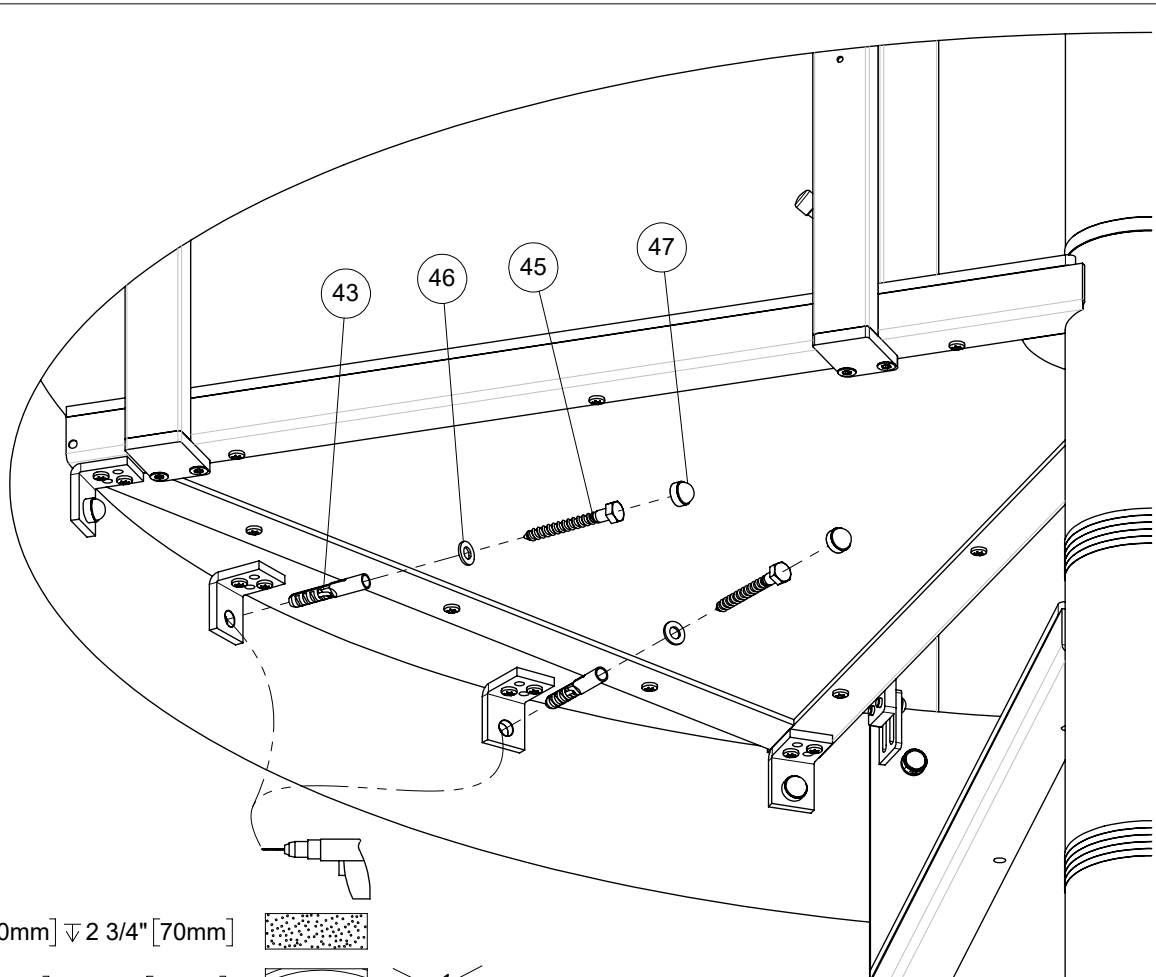

2 x  $\varnothing 3/8"$  [10mm]  $\nabla 2 3/4"$  [70mm]



2 x  $\varnothing 1/4"$  [6mm]  $\nabla 2 3/4"$  [70mm]



46

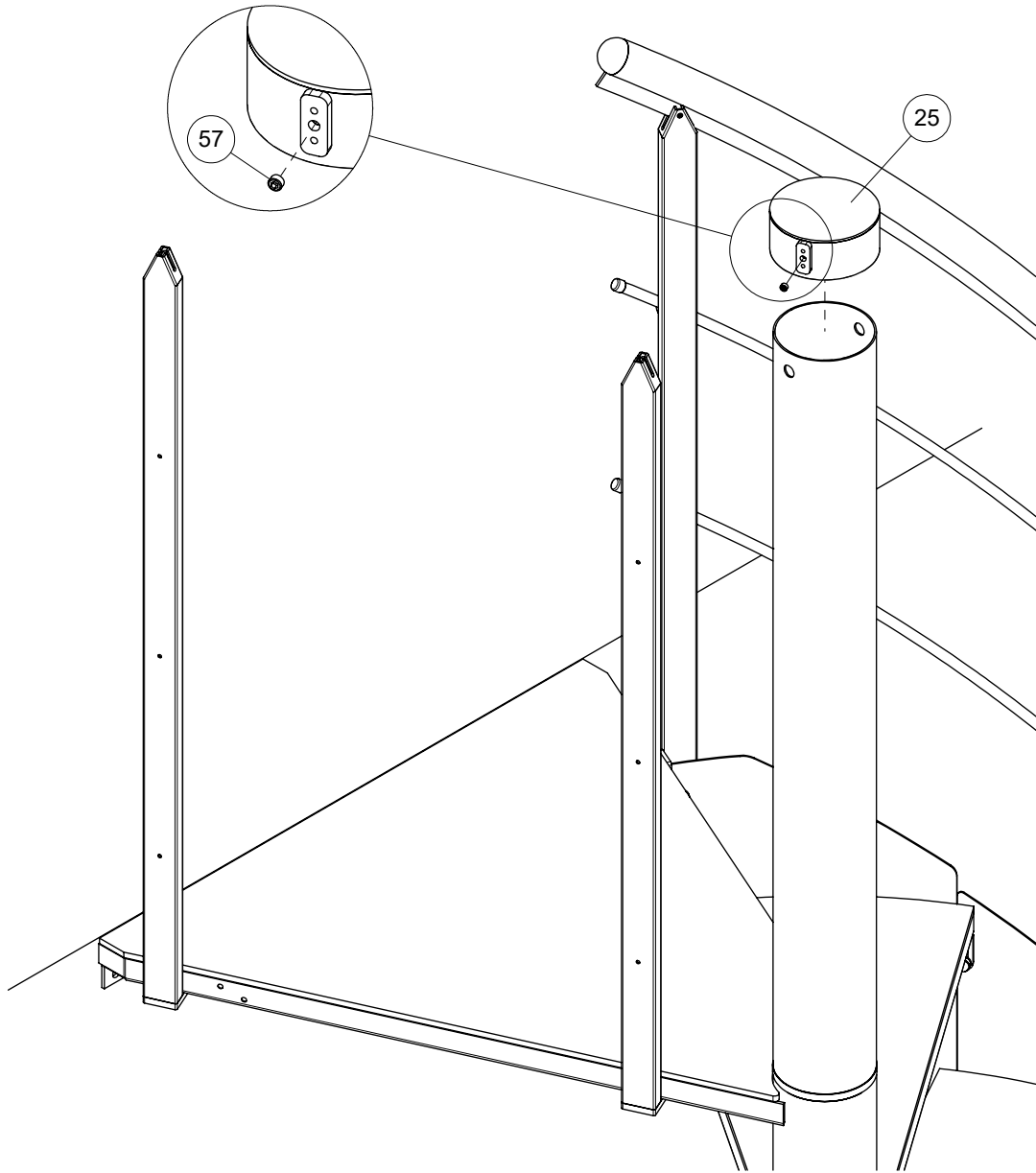

47

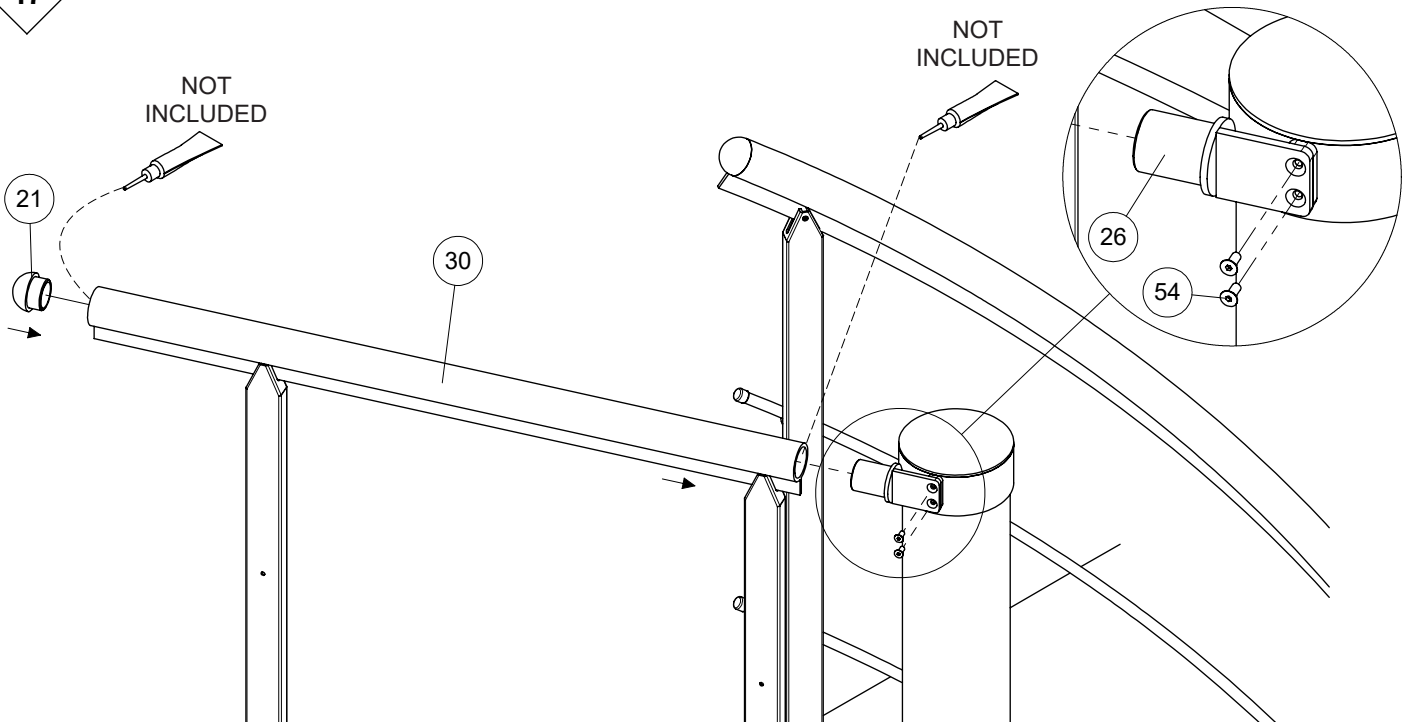

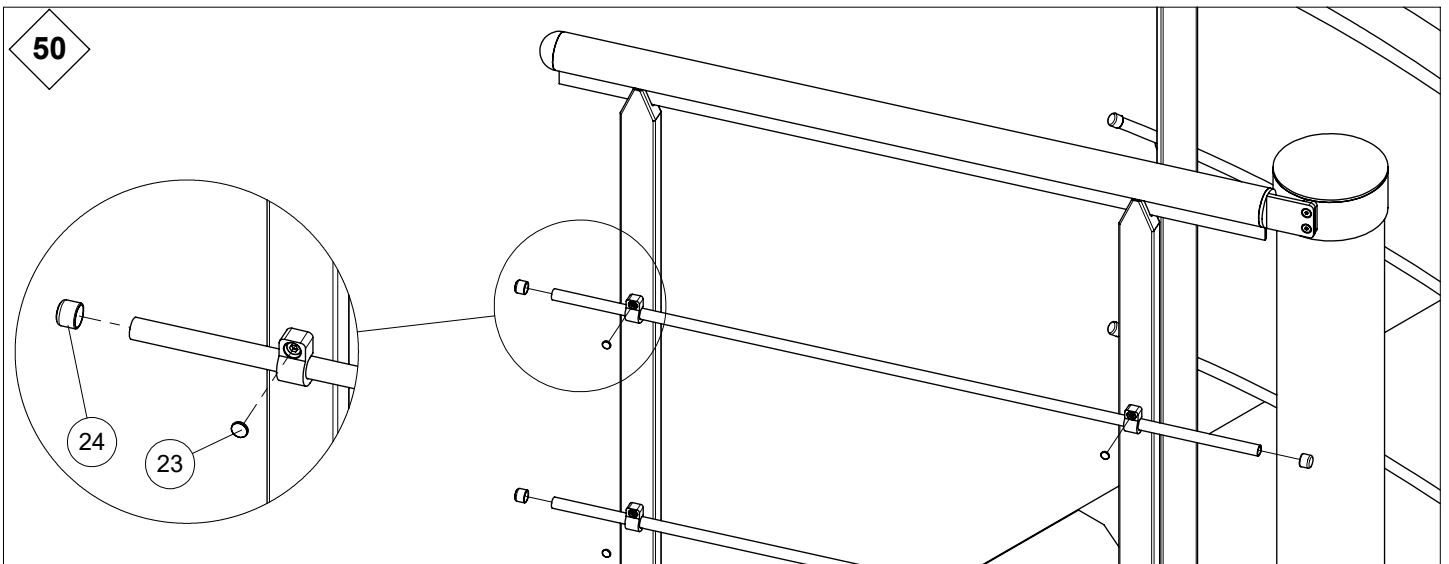
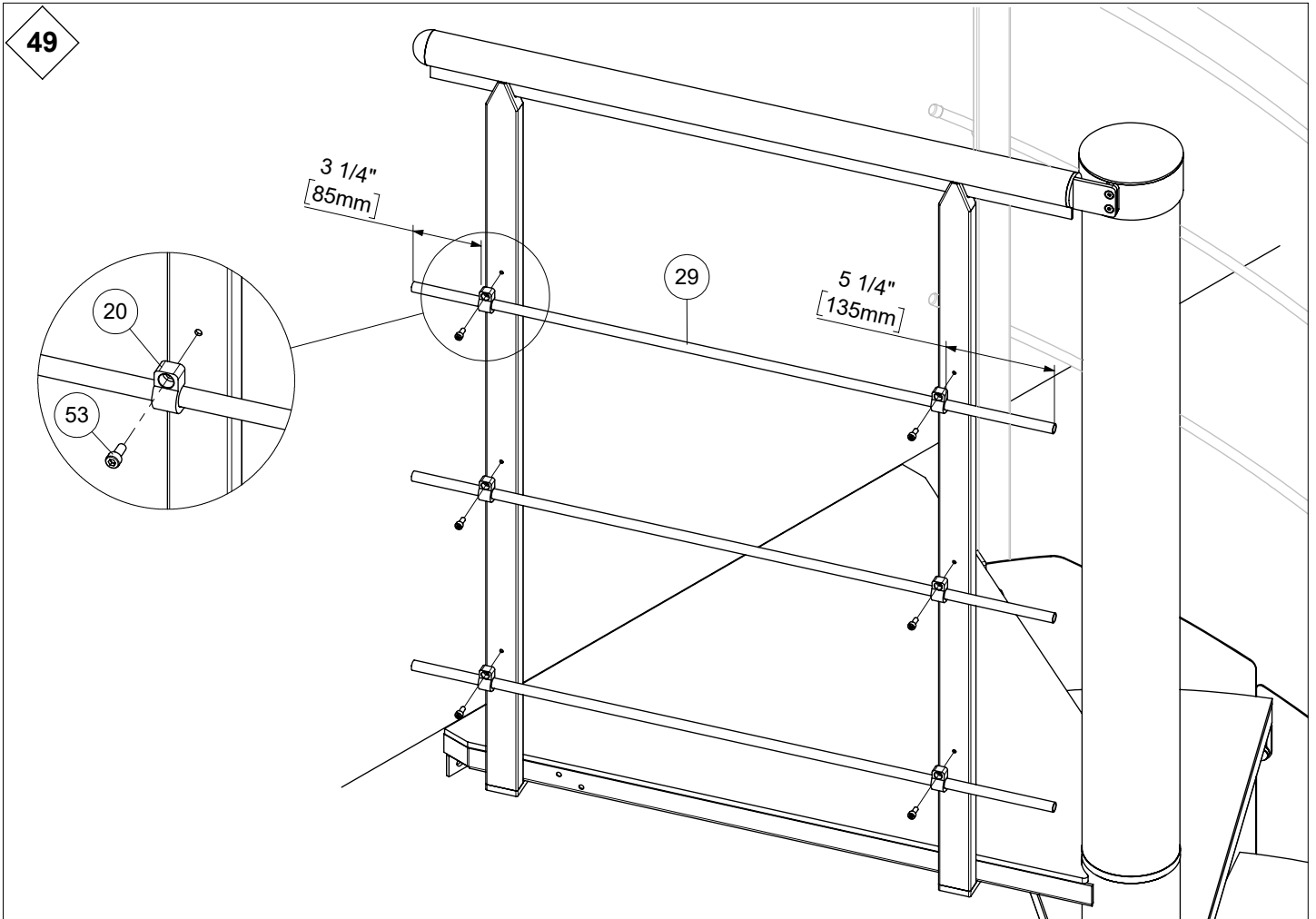
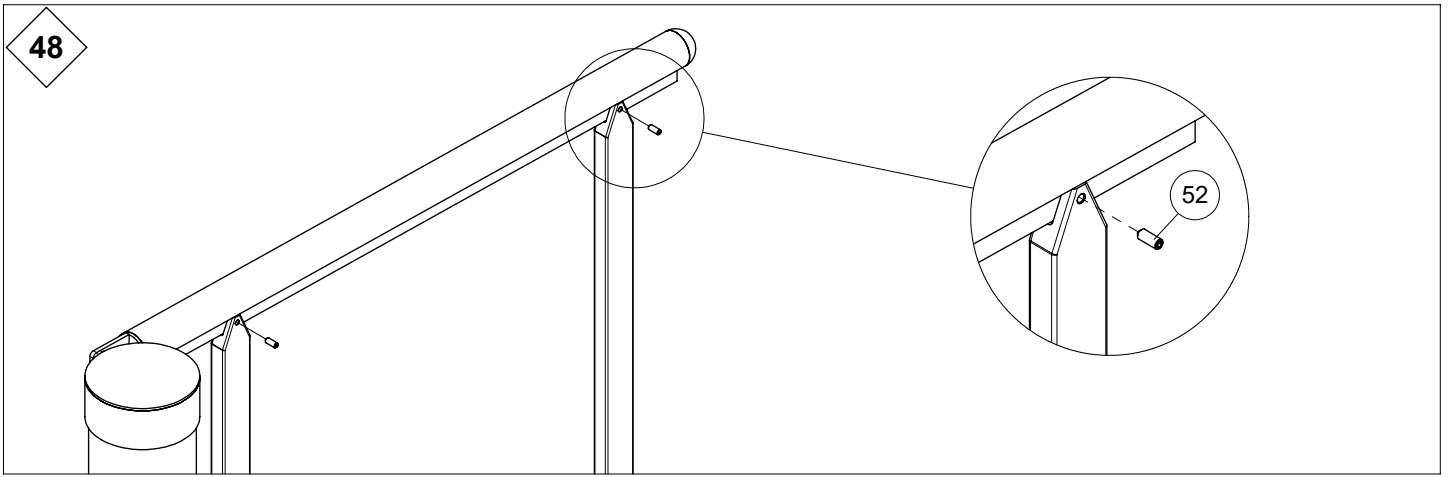

51

